



Échelon™ Series



Installation Guide

2075DWRWC — Drawer Model Wine Captain®

www.U-LineService.com

Phone (414) 354-0300 • FAX (414) 354-7905
Service & Parts Tech Lines Phone (800) 779-2547 • FAX (414) 354-5696
OnlineService@U-Line.com

©2005 U-Line Corporation
02/2005

Contents

Exterior Cleaning 4
 Cut-Out Dimensions 4
 Product Dimensions 5
 Clearances Information 5
 Other Site Requirements 6
 Adding a Final Finish Coat to Wood Trim 7
 Staining Wood Trim a Different Color 7
 Checking Drawer Alignment 8
 Adjusting Drawer Alignment 8
 Electrical Specifications 11
 Leveling Information 11
 Installation Tip 11
 Installation of the 2075DWRWC 12
 Anti-Tip Kit Installation 12
 Installation Troubleshooting 13
 Initial Start-Up 13
 Start-Up Troubleshooting 14
 Service Information 15

1 Follow Safety Precautions

IMPORTANT

PLEASE READ all instructions completely before attempting to install or operate the unit.

- This unit requires connection to a grounded (three-prong), polarized receptacle that has been placed by a qualified electrician in accordance with applicable electrical codes.

Safety Alert Definitions

Safety items throughout this guide are labeled with a Danger, Warning or Caution based on the risk type:

⚠ DANGER

Danger means that failure to follow this safety statement will result in severe personal injury or death.

⚠ WARNING

Warning means that failure to follow this safety statement could result in serious personal injury, or death.

⚠ CAUTION

Caution means that failure to follow this safety statement may result in minor or moderate personal injury, property or equipment damage.

General Precautions

Use this appliance for its intended purpose only and follow these general precautions along with those listed throughout this guide:

WARNING

SHOCK HAZARD — Electrical Grounding Required.

- **Keep the unit unplugged throughout installation except during testing.**
- **Never remove the round grounding prong from the plug and never use a two-prong grounding adapter.**
- **Never use an extension cord to connect power to the unit.**
- **Always keep your working area dry.**

WARNING

The Anti-Tip Kit must be installed on this unit before it is used. Never use the drawers as steps or as a shelf to support more than the drawers' contents. Serious personal injury could occur.

CAUTION

- Use care when moving and handling the unit. Use gloves to prevent personal injury from sharp edges.
- Do not lift the unit by the drawer handle.
- Do not install the unit behind closed doors or in any way that would obstruct airflow to the front grille, which may cause the unit to malfunction.

2 Inspect and Plan

You have received a carton containing your 2075DWRWC Drawer Model Wine Captain® with a package inside containing a User Manual, a Product Registration Card and Anti-Tip Kit. Complete and mail the Product Registration Card or register online at www.U-LineService.com. Once your unit is installed, keep the User Manual and this Installation Guide in a safe place for future reference.

Your unit is Black or Stainless Steel. Black units have drawers with black glass fronts, sculpted handles and black vinyl-clad cabinets. Stainless Steel units have drawers with stainless steel framed fronts, sculpted stainless steel handles and black vinyl-clad cabinets. All units come with maple trim wine racks and caddy that can be finished or stained. Please carefully follow the directions that apply to your unit and your intended design.

Tools/Materials Required

- Wrenches
- Screwdrivers — slotted and Phillips head
- Sandpaper; low odor, water clean up, quick drying finish; tack cloth and, if desired, water-based wood stain and synthetic foam brush

Inspection

Unwrap and inspect the unit on a flat, level surface capable of supporting its entire weight.

Removing Protective Coating

Stainless Steel Models:

When inspecting/installing a Stainless Steel unit, the protective coating covering the drawer fronts must be removed. Start at a corner of the drawers and pull back the protective coating to remove it from the drawer fronts.

After all the protective coating has been removed from the drawers, clean all Stainless Steel surfaces with Claire Stainless Steel Polish and Cleaner or comparable product or a mild detergent and warm water solution and soft cloth. Do NOT use abrasive cleaning agents.

Note: If cleaning with mild detergent and warm water solution and soft cloth, the unit **MUST** be treated with Claire Stainless Steel Polish and Cleaner or comparable product to prevent discoloration.

Clean all glass surfaces with a non-chlorine glass cleaner.

Exterior Cleaning

(As Required)

Black Models:

- Clean glass drawer fronts with glass cleaner. The drawers, grille and cabinet may be cleaned with a mild detergent and warm water solution. Do not use solvent-based or abrasive cleaners. Use a soft sponge and rinse with clean water. Wipe with a soft, clean towel to prevent water spotting.

Stainless Steel Models:

- Stainless steel models can discolor when exposed to chlorine gas, pool chemicals, salt water or cleaners with bleach.
- Clean glass drawer fronts with a non-chlorine glass cleaner. Keep your stainless steel surfaces looking new by cleaning with a good quality all-in-one stainless steel cleaner/polish on a monthly basis. For best results use Claire Stainless Steel Polish and Cleaner, which can be purchased from U-Line Corporation. (The part number is 173348.) Comparable products are acceptable. Frequent cleaning will remove surface contamination that could lead to rust. Some installations may require cleaning on a weekly basis.
- **Do not clean with steel wool pads.**
- **Do not use stainless steel cleaners/polishes on the glass surfaces.**
- **Do not use cleaners that are not specifically intended for stainless steel on stainless steel surfaces (this includes glass, tile and counter cleaners).**
- If any surface discolors or rusting appears, clean it quickly with Bon-Ami or Barkeepers Friend Cleanser and a non-abrasive cloth. Always clean in the direction of the grain. Always finish this process with Claire Stainless Steel Polish and Cleaner or comparable product to prevent further problems.
- **Use of abrasive pads such as Scotchbrite will cause the graining in the stainless to become blurred.**
- Rust that is allowed to linger can penetrate into the surface of the stainless steel and complete removal of the rust may not be possible.

3 Prepare Site

Your U-Line product has been designed for built-in installation. Your unit does not require additional air space for top, sides or rear. However, the front grille must NOT be obstructed and clearance is required for electrical connection in the rear.

Note: Unit can NOT be installed behind a closed cabinet door.

Cut-Out Dimensions

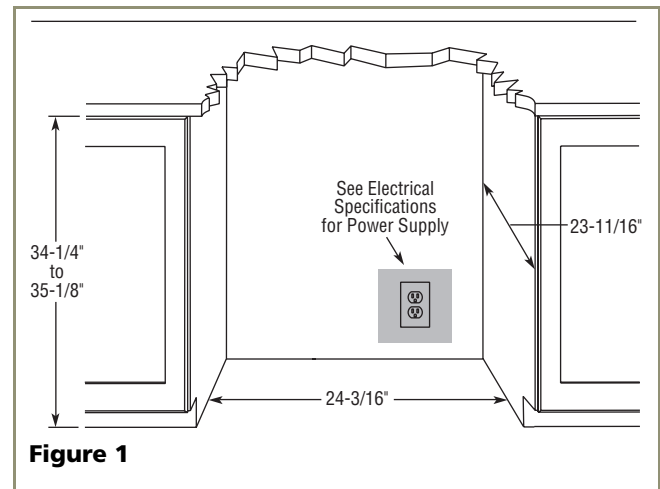
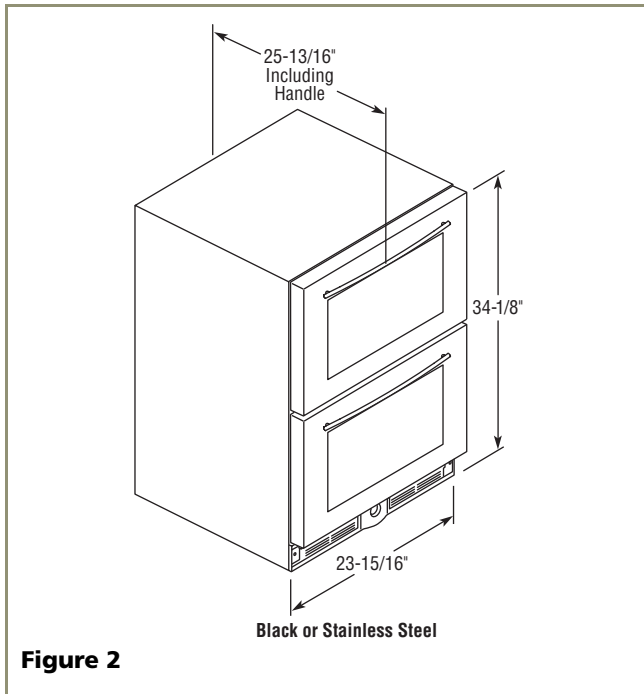

Figure 1

Follow the cut-out drawing in **Figure 1**. The 24-3/16" width allows 1/4" for ease in installation and removal of the unit. 24" is the counter depth in most installations. The unit is 23-11/16" deep including the drawer and not the full handle (see **Figure 2**).

Product Dimensions



Please note that the unit has adjustable feet that can add one additional inch to height during leveling or to match adjacent cabinets (see **Figure 19** on **Page 11**).

Clearances Information

The unit must be installed in a wall or under a countertop to allow for the installation of the Anti-Tip Kit (see **Page 12**).

WARNING

The Anti-Tip Kit must be installed on this unit before it is used. Never use the drawers as steps or as a shelf to support more than the drawers' contents. Serious personal injury could occur.

The unit is designed so it can be installed next to a wall on either side (see **Figure 3**).

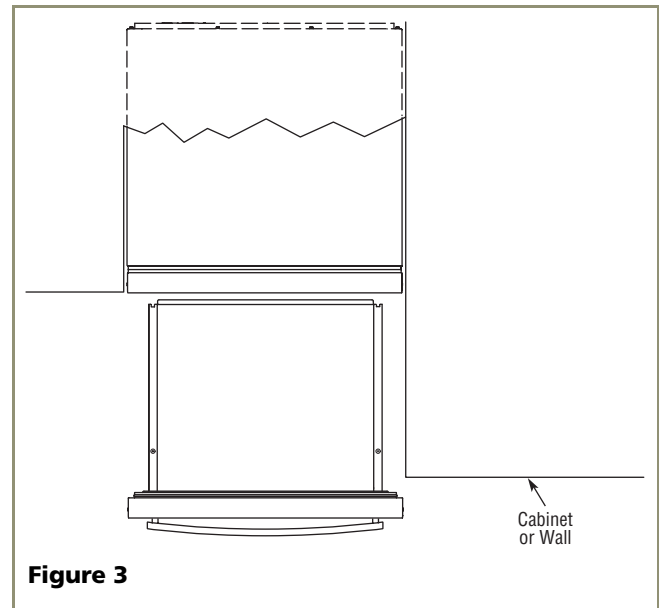

The drawer unit can be installed with an appliance or fixture located in front of it, as long as there is adequate clearance for the drawer to be opened and removed when servicing (see **Figure 4**).

Note: U-Line recommends you consider additional clearance in front of the open drawer for convenience.

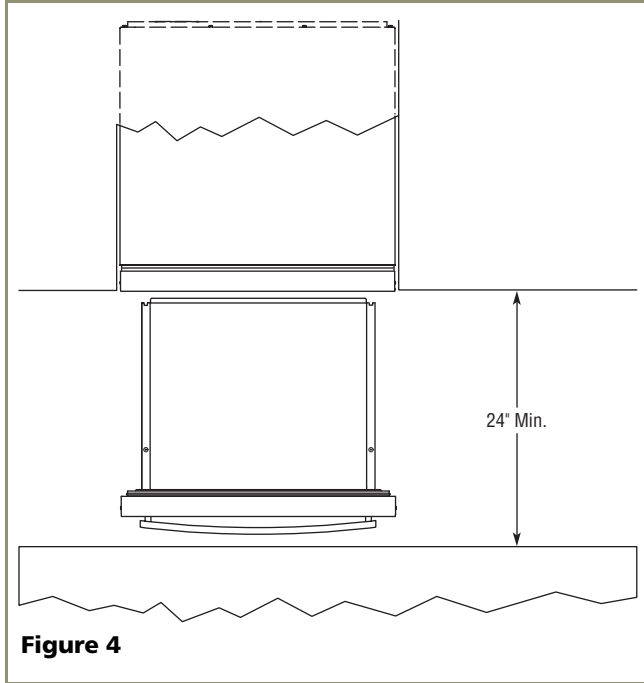

Other Site Requirements

Power Supply

The unit requires a grounded and polarized 115 VAC, 60 Hz, 15A circuit (normal household current). See *Electrical Specifications* on **Page 11**.

Environmental Requirements

The surrounding air temperature must be at least 50°F (10°C) but must not exceed 110°F (40°C). Units may be installed outdoors in a covered area. The unit must not be located near heat-generating equipment or in direct sunlight.

4 Prepare Racks and Caddy

The U-Line Wine Captain® is equipped with wood-trimmed wine racks that are coated at the factory with a clear vinyl sealer, which will adequately protect the wood in normal usage. A final finish coat was not applied so that the wood trim could be stained to match décor. The trim on the racks may be coated with a final finish or stained.

If neither of these treatments are to be included in this installation, go on to **5 Adjust Drawers**.

CAUTION

To prevent permanent damage to the inner liner of the Wine Captain®, the wine rack wood trim **MUST** be removed from the unit for staining and/or finishing. Allow stain/finish to dry thoroughly (at least 24 hours per coat) in accordance with the stain/finish manufacturer's instructions prior to re-installing the wood trim inside the cabinet of the Wine Captain®. Failure to do so may cause the inner liner of the unit to have a permanent odor, which is not covered by the warranty.

Adding a Final Finish Coat to Wood Trim

IMPORTANT

Do not remove the two racks attached at the drawer slides.

1. Remove wine caddy, the top two racks in the upper drawer and the top rack in the bottom drawer (remove each wine rack by sliding it out and up). See **Figure 5**.
2. Remove and save screws securing wood trim to the racks and caddy.
3. Remove and save screws securing wood trim to the two racks attached at the drawer slides (without removing these racks themselves).
4. Lightly scuff sand the wood trim with 280 grit 3M Tri-M-Ite sandpaper.
5. Remove sanding dust with a tack cloth.
6. Apply a thin coat of Minwax Polycrylic, following container label for directions. Allow to dry 24 hours.

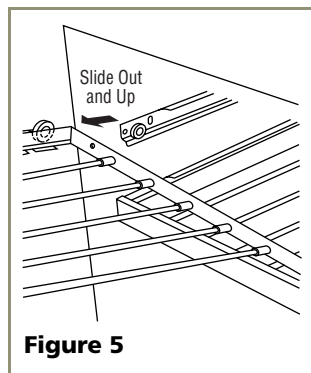

7. Lightly sand, tack and reapply 2 times, if desired.
8. Allow the final coat to dry for 24 hours.
9. Reinstall wood trim to wine racks and caddy using screws removed in Steps 2 and 3.
10. Reinstall the removed wine racks and caddy in unit.
11. Go on to **5 Adjust Drawers**.

Staining Wood Trim a Different Color

IMPORTANT

Do not remove the two racks attached at the drawer slides.

1. Remove wine caddy, the top two racks in the upper drawer and the top rack in the bottom drawer (remove each wine rack by sliding it out and up). See **Figure 5**.
2. Remove and save screws securing wood trim to the racks and caddy.
3. Remove and save screws securing wood trim to the two racks attached at the drawer slides (without removing these racks themselves).
4. Apply Minwax Water-Based Wood Stain to wood with a synthetic foam brush. Stain must penetrate approximately 3 minutes. After this period, while stain is still wet, take a stain-dampened rag and remove all excess stain. Wipe in the direction of the grain with medium pressure to achieve the desired stain color.
5. After 2 hours, repeat Step 4.
6. Allow stain to dry for a minimum of 3 hours before finishing.
7. Sand the wood with very fine sandpaper to smooth the surface from the staining process.
8. Remove sanding dust with a tack cloth.
9. Apply a thin coat of Minwax Polycrylic, following container label for directions. Allow to dry 24 hours.
10. Lightly sand, tack and reapply 2 times, if desired.
11. Allow the final coat to dry for 24 hours.
12. Reinstall wood trim to wine racks and caddy using screws removed in Steps 2 and 3.
13. Reinstall the removed wine racks and caddy in unit.
14. Go on to **5 Adjust Drawers**.

5 Adjust Drawers

Checking Drawer Alignment

The unit's drawers are aligned at the factory before shipment. However, their alignment could have been disturbed during shipment.

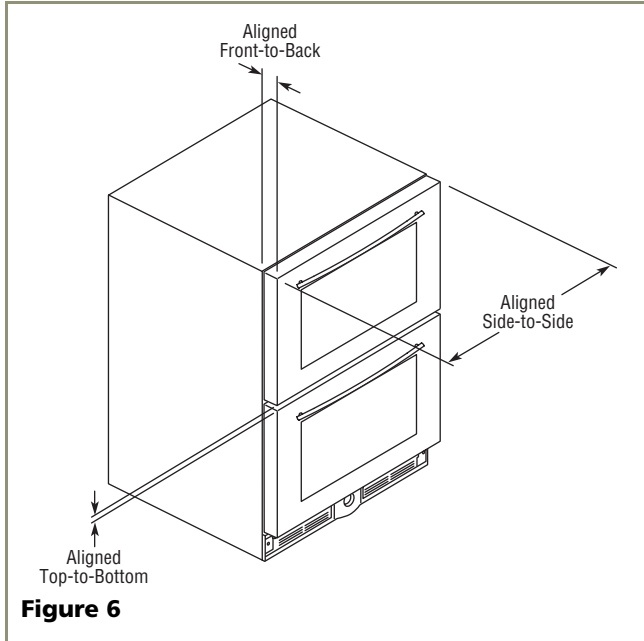

See **Figure 6**. Check each drawer to confirm that it is aligned:

- **Side-to-Side** — When viewed from the top, the drawer front should be square with the sides of the cabinet.
- **Front-to-Back** — When viewed from the side, the drawer front should be straight with the cabinet's sides, not cocked forward or back.
- **Top-to-Bottom** — When viewed from the front, the drawer should be level horizontally.

If both drawers are properly aligned, go on to **6 Prepare Power Supply**. If either drawer is not aligned, carefully follow instructions to remove that drawer, make the necessary adjustment and re-install the drawer.

Adjusting Drawer Alignment

⚠ WARNING

SHOCK HAZARD — The unit must be unplugged from the wall outlet during drawer removal, adjustment and re-installation.

Drawer Removal

1. Confirm that the unit is unplugged from wall outlet.
2. Unplug the drawer's connection wiring (top drawer only).
3. Remove the mounting screws. See **Figure 7**.
4. Pull the drawer completely out of the unit.

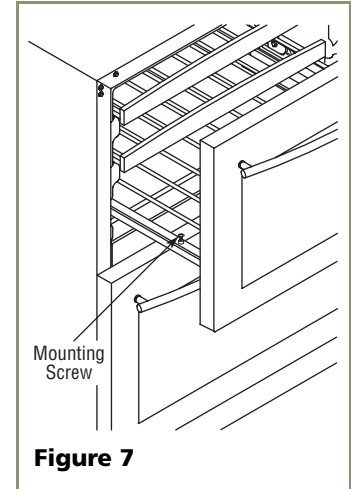

⚠ CAUTION

Use care when handling the drawer. Drawer edges, drawer rail and the unit's slide may be sharp.

IMPORTANT

Drawer adjustments are made by moving the slide that carries the drawer's rail. Minor adjustments may be made by loosening one of the slide's mounting screws, adjusting the slide and retightening the screw. Severe adjustments may be made by removing the slides' mounting screws, drilling new mounting holes and remounting the slide.

Side-to-Side Adjustment

See **Figure 8**. The drawer will need a Side-to-Side Adjustment if, when viewed from the top, the drawer front is not square with the sides of the cabinet. This is caused by one of the slides being mounted too far forward on the unit's liner.

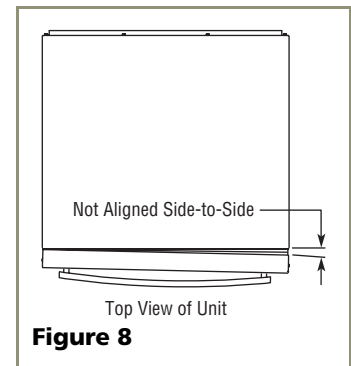

Minor Adjustment:

Note: The mounting holes on the slide are slightly larger than the screws' diameter.

1. Loosen the slide's mounting screws.
2. Push the slide backward.
3. Retighten the screws. See **Figure 9**.

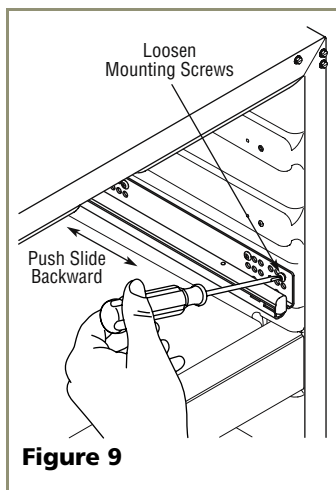

Severe Adjustment:

Note: The slides have extra mounting holes that may be used.

1. Remove the slide's mounting screws.
2. Reposition the slide so it is the same distance from the front of the liner as the other slide. Measure to confirm.
3. Mark new drilling holes using different sets of mounting holes on the slide. See **Figure 10**.

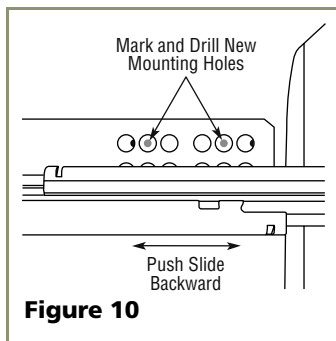

Note: Front location holes are shown. Corresponding rear holes will also need to be marked.

4. Drill all the new holes with a #30 drill bit.
5. Remount the slide.

Front-to-Back Adjustment

See **Figure 11**. The drawer will need a Front-to-Back Adjustment if, when viewed from the side, the drawer front is cocked forward or back. This is caused by the front slide mountings not being level with the rear slide mountings.

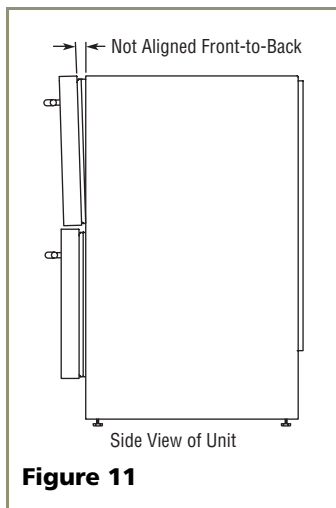

Minor Adjustment:

Note: The mounting holes on the slide are slightly larger than the screws' diameter.

1. Loosen one slide's mounting screws.
2. Level the slide.
3. Retighten the screws. See **Figure 12**.
4. Repeat procedure for the other slide.

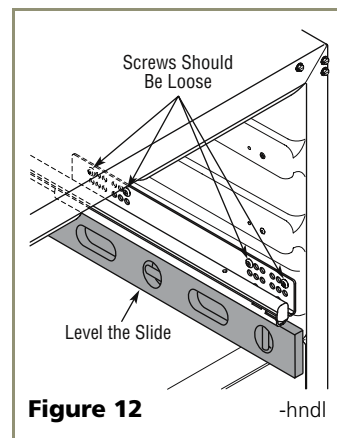

Severe Adjustment:

Note: The slides have extra mounting holes that may be used.

1. Loosen one slide's rear mounting screws.
2. Remove the slide's front mounting screws.
3. Reposition the slide so it is level.
4. Mark new front drilling holes using a different set of mounting holes on the slide. See **Figure 13**.
5. Drill the new holes with a #30 drill bit.
6. Remount the slide.
7. Repeat procedure for the other slide.

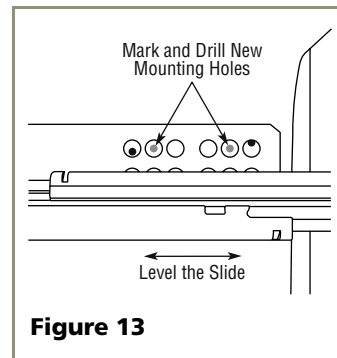

Top-to-Bottom (and Left-to-Right) Adjustment

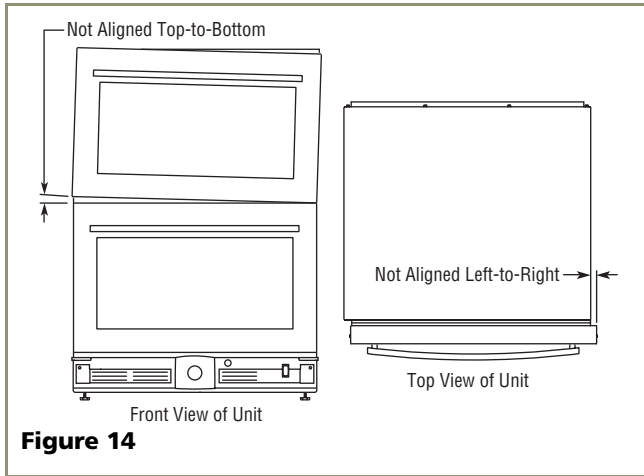

See **Figure 14**. The drawer will need a Top-to-Bottom Adjustment if, when viewed from the front, the drawer is not level horizontally. Viewed from the top, one side will protrude. This is caused by one of the slides being mounted higher than the other slide on the unit's liner.

Minor Adjustment:

Note: The mounting holes on the slide are slightly larger than the screws' diameter.

1. Loosen one slide's mounting screws.
2. Push the slide upward or downward to match the position of the other slide.
3. Retighten the screws. See **Figure 15**.
4. Repeat the procedure with the other slide if necessary.

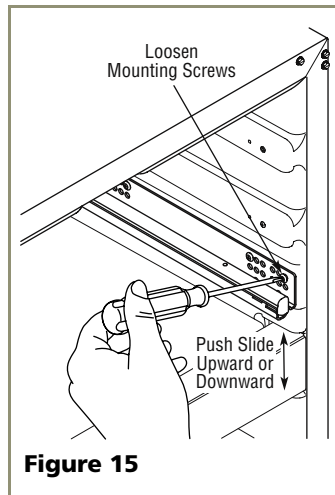

Severe Adjustment:

Note: The slides have extra mounting holes that may be used.

1. Remove one slide's mounting screws.
2. Reposition the slide so it is the same distance from the bottom of the liner as the other slide. Measure to confirm.
3. Mark new drilling holes using different sets of mounting holes on the slide. See **Figure 16**.

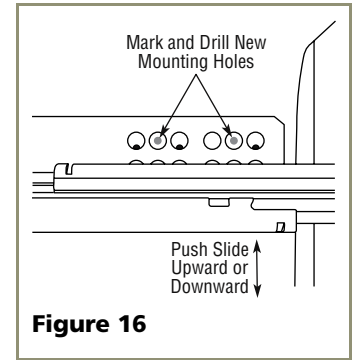

Note: Front location holes are shown. Corresponding rear holes will also need to be marked.

4. Drill all the new holes with a #30 drill bit.
5. Remount the slide.

Re-installation of Drawer



Use care when handling the drawer. Drawer edges, drawer rail and the unit's slide may be sharp.

1. Set the drawer's rails onto the slides.
2. Re-install the rails' mounting screws. See **Figure 7** on **Page 8**.
3. Plug in the drawer's connection wiring (top drawer only).
4. Go on to **6 Prepare Power Supply**.

6 Prepare Power Supply

Electrical Specifications

⚠ CAUTION

Electrical installation must observe all state and local codes. This unit requires connection to a grounded (three-prong), polarized receptacle that has been placed by a qualified electrician.

The unit requires a grounded and polarized 115 VAC, 60 Hz, 15A power supply (normal household current). An individual, properly grounded branch circuit or circuit breaker is recommended. GFCI (ground fault circuit interrupter) is usually not required for fixed location appliances and is not recommended for your unit because a GFCI could be prone to nuisance tripping. However, be sure to consult your local codes.

See **Figure 17** for recommended receptacle location.

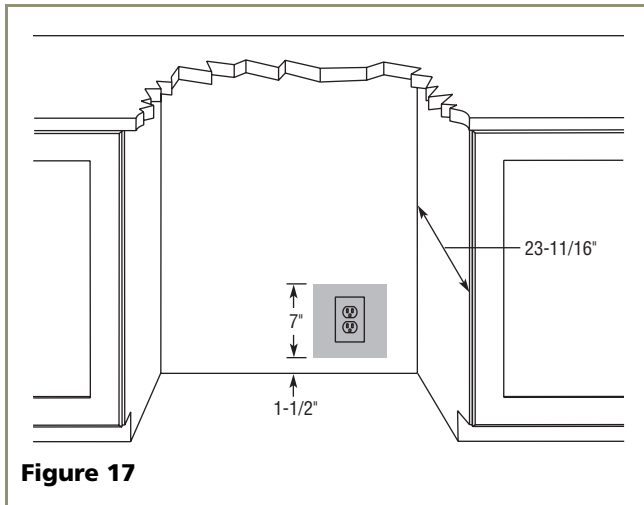

Figure 17

⚠ WARNING

SHOCK HAZARD — Electrical Grounding Required.

- Never remove the round grounding prong from the plug and never use a two-prong grounding adapter.
- Never use an extension cord to connect power to the unit.

Go on to **7 Level the Unit**.

7 Level the Unit

Leveling Information

Note: It is recommended that the unit is level.

1. Use a level to check the levelness of the unit from front to back and from side to side. Level should be placed along top edge and side edge as shown (see **Figure 18**).

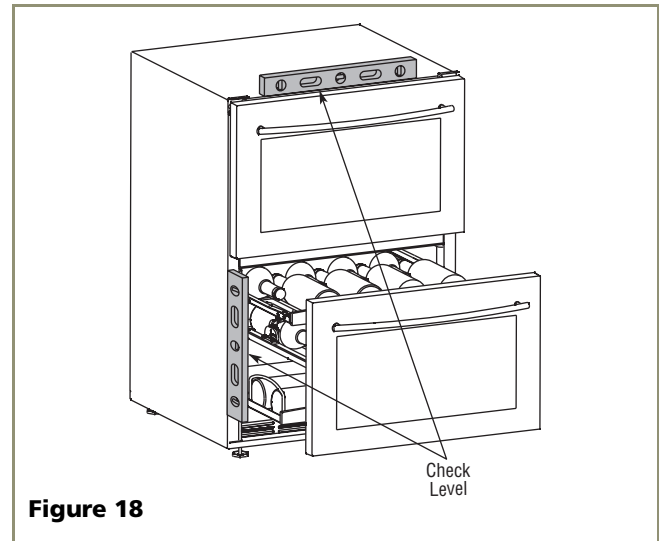

Figure 18

2. If the unit is not level, adjust the feet on the corners of the unit as necessary (see **Figure 19**).

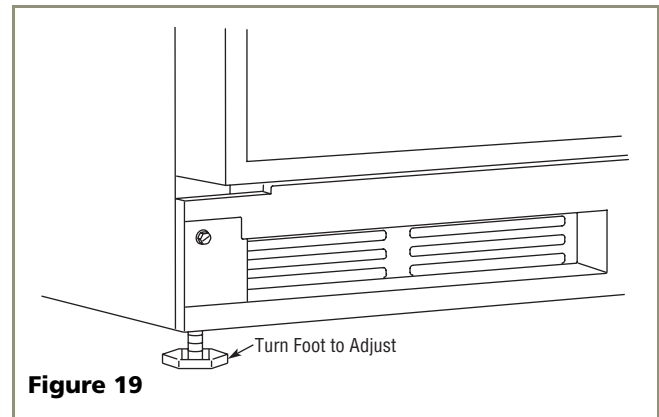

Figure 19

3. Check the levelness after each adjustment and repeat the previous steps until the unit is level. Go on to **8 Install the Unit**.

Installation Tip

If the room floor is higher than the floor in the cut-out opening, adjust the rear feet to achieve a total unit rear height of 1/8" less than the opening's rear height. Shorten the unit height in the front by adjusting the front feet. This allows the unit to be gently tipped into the opening. Readjust the front feet to level the unit after it is correctly positioned in the opening.

8 Install the Unit

Installation of the 2075DWRWC

1. Plug in the power cord.
2. Gently push the unit into position. Be careful not to entangle the electrical cord.
3. Re-check the leveling, from front to back and side to side. Make any necessary adjustments. The unit's top surface should be approximately 1/8" below the countertop.

Anti-Tip Kit Installation

⚠ WARNING

- **The Anti-Tip Kit must be installed on this unit before it is used.**
- **Additional blocking or special fasteners may be required for installation. Installer is responsible for secure attachment to prevent the unit from tipping.**
- **Make sure the mounting screws attaching the unit to the counter, cabinet or wall are deep enough into the mounting surface to support the weight of the drawers and the items that will be inside the drawers.**
- **Never use the drawers as steps or as a shelf to support more than the drawers' content. Serious personal injury could occur.**

After leveling, the unit must be secured to a counter, a cabinet or a wall to prevent tipping.

1. Open the upper drawer to expose the six screws (A) installed at the top two corners (three at each corner). Remove the appropriate screws for horizontal or vertical mounting (see **Figure 20**). Do not discard.

Horizontal Mounting (Left Side Shown)

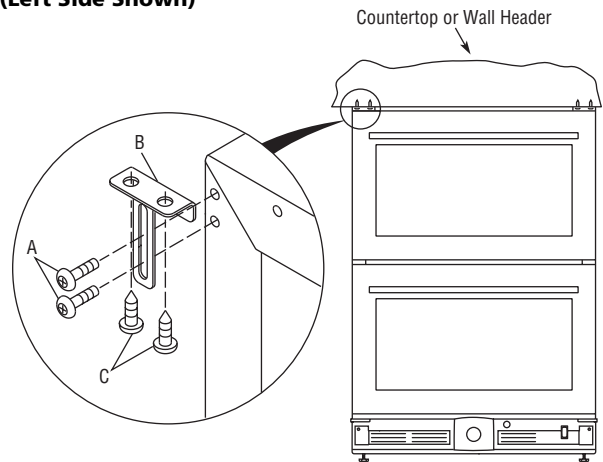

Vertical Mounting (Left Side Shown)

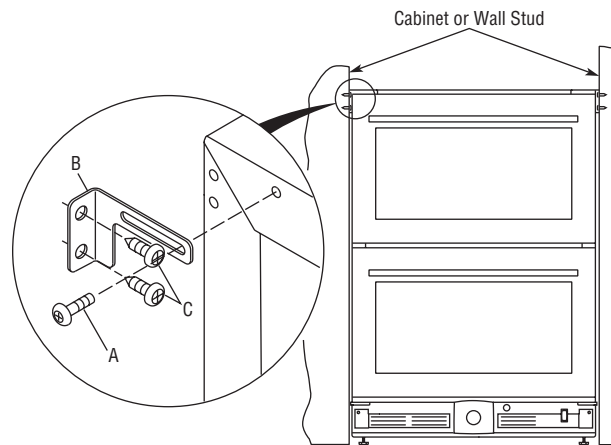

Figure 20

2. Insert the screws through the anti-tip bracket (B) and attach the bracket to the unit. Tighten screws securely.
3. Repeat for the other side.

Note: The bracket should be flush with the surface it is being attached to. If it is not, loosen the screws and slide the bracket against the mounting surface. Tighten screws securely.

4. Using two of the screws (C) supplied, fasten the screws through the bracket and into the counter, cabinet or wall.

IMPORTANT

Certain cabinets or countertops may require special fasteners or additional wood blocking to anchor properly.

CAUTION

Make sure the screws are back far enough so they do not damage any exposed front surface of the cabinet.

Installation Troubleshooting

Q: Problem

The drawer remains open unless it is pushed closed.

A: Solution

The drawer should be self-closing when it is open approximately 8". If it is not, re-check leveling from front to back of the unit and readjust if necessary.

9 Start-Up for the First Time

Initial Start-Up

Once installation and leveling is complete, the unit is ready for initial start-up and operation.

Temperature Controller

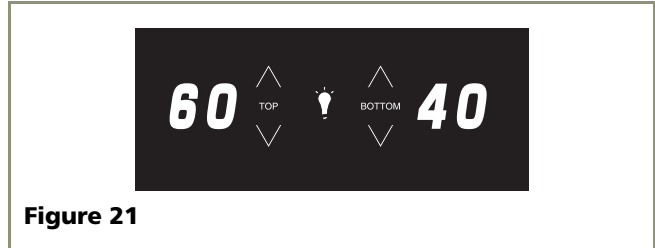

Figure 21

The temperature controls are integrated in the top, front drawer panel. They consist of an LED display and touch sensors for each drawer and a touch sensor to control the lighting ("^", "v" and "💡"). The LED displays show the drawer's temperature set point, and are calibrated in degrees Fahrenheit. The controls are factory programmed for a set point of 60°F for the top drawer and 40° F for the bottom drawer. Each drawer's display will show its set point when the unit is first powered up.

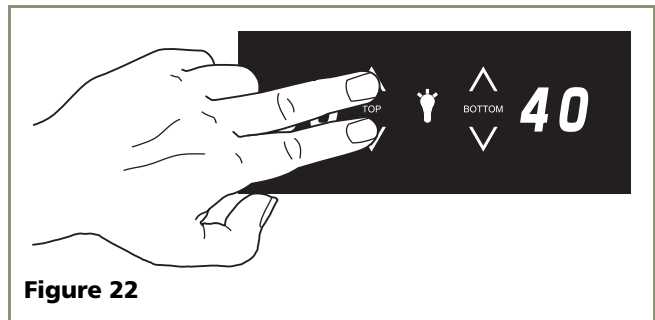

Figure 22

To display actual temperature of each drawer, press the “^” and “v” touch sensors simultaneously for three seconds. The display indicates the actual temperature. After approximately 10 seconds, the set point temperature displays.

To adjust the temperature set point, touch and hold either the “^” or “v” for that drawer for three seconds. When the LED displays “SP,” lift your finger from the controller and the corresponding LED will begin to flash the set point. Touch the “^” or “v” until the desired set point displays. Wait 10 seconds for the new set point to be saved. Wait 24 hours for the temperature to stabilize before checking the actual temperature again. Each wine compartment can be set to 40°F to 60°F.

Note: A flashing indicator light (LED dot) indicates a thermistor error in that drawer. Call for service.

Other Settings

Other settings for the unit are factory preset. No adjustments should be necessary at this time. See the User Manual for information on:

- Adjusting the interior lighting
- Removing the lower drawer’s wine caddy
- Using or disabling the cascade feature

Start-Up Troubleshooting

Q: Problem

Unit does not appear to turn on when plugged in.

A: Solution

Make sure outlet has power (circuit breaker has not tripped).

IMPORTANT

See the User Manual’s *Troubleshooting Guide* for more solutions.

Échelon™ Series

Who to Call

Service Information

If the need for service arises, contact the dealer from whom the unit was purchased. State the Model Number and Serial Number and explain the problem. The Model and Serial Number plate is located inside unit at upper right hand corner.

If you need to locate a service company, you can go online at **www.U-LineService.com** and search for a service company by zip code.

For more than four decades, U-Line has distinguished itself as the leader in built-in undercounter ice making, refrigeration and wine storage appliances.

Échelon™ SERIES / *O r i g i n s* SERIES

U-Line Corporation, located in Milwaukee, WI, is a family operated manufacturer of built-in undercounter icemakers, Combo® icemaker/refrigerators, Wine Captain® wine storage units, refrigerators, refrigerated drawers and refrigerator/freezers.