

## Model 2075DWRR Drawer Refrigerator

See Overlay Door Panel Preparation Instructions

A 5.5 cubic foot built-in under the counter refrigerated drawer unit.

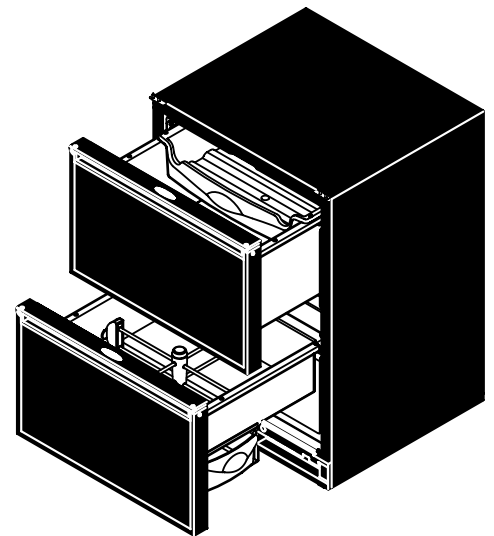
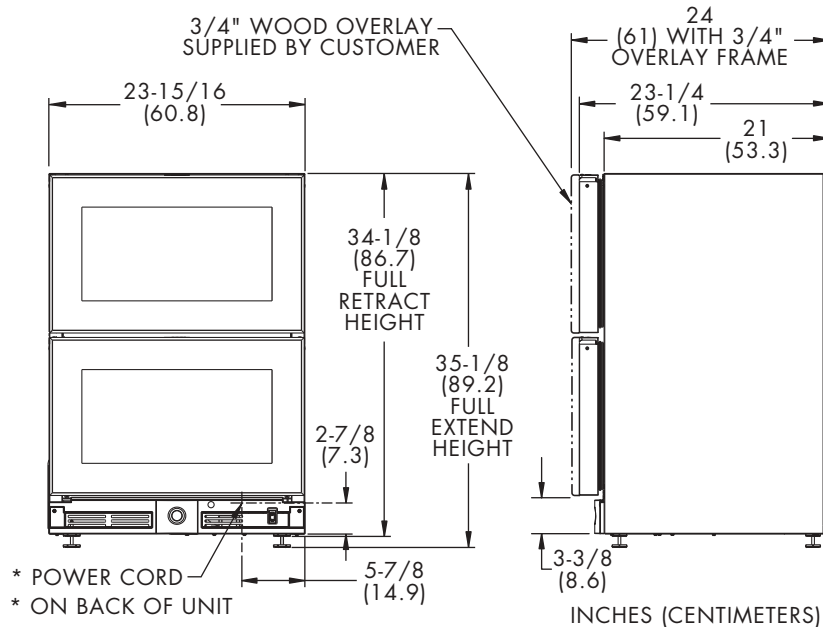

## EXCLUSIVE FEATURES OF ÉCHELON™

### 1. Just under 24 inches wide

**BENEFIT:** Fits into a standard 24 inch wide cabinet opening.

### 2. Multiple organizing features

- Adjustable Slide & Divide organizer comes standard in the top drawer and can be used in either drawer. Consumer can adjust the organizer from front to back, and side to side.
- Clear organizing bin for top drawer can accommodate wine bottles, two-liter bottles, or other items. The bin is designed to slide from the front to rear of the drawer allowing easy access to items in or beneath the bin.
- Bottom drawer crisper can be removed from either side of the drawer to easily bring fruit or vegetables to a sink, counter top, or bar.
- Glass crisper shelf allows customer to easily see contents of the crisper. Crisper shelf can easily be fully removed to accommodate storage of taller items.

**BENEFIT:** Use of all organizing features allow consumers to customize their refrigeration space.

### 3. Stainless steel units come standard with a seamless full wrap stainless steel drawer front, sculpted stainless handles and a black vinyl clad cabinet.

**BENEFIT:** The seamless full wrap stainless steel drawers with sculpted handles distinguish this unit from heavier, "commercial" looks and reduces assembly time in the field and overall cost.

### 4. Stainless steel drawer interiors

**BENEFIT:** Corrosion resistant, sleek professional appearance.

### 5. Consumer friendly, self diagnosing controller

**BENEFIT:** In the rare event of a problem, a flashing LED indicator light explains if there is a need to call for service.

# SUPERIOR FEATURES OF ÉCHELON™

---

1. **Easy to set, adjustable, LED temperature controller**

**BENEFIT:** Digital readout of temperature setting and actual drawer temperatures. Easy ability to see and adjust to desired temperature.

2. **Black units come standard to accept a full overlay drawer panel**

**BENEFIT:** Provides a fully integrated appearance with surrounding cabinetry. Overlay panels are easily attached to drawers.

3. **Full overlay capability allows the customer to choose the size of the gap between drawer panels (either 1/2 or 1/4 inch gap)**

**BENEFIT:** This provides the customer greater flexibility in matching surrounding cabinetry.

4. **Black units come with flush mounted black drawer panel and will accept a custom 1/4 inch thick panel**

**BENEFIT:** Allows customer to achieve a custom, built-in look by matching surrounding cabinetry. Drawers come standard from the factory equipped to be used with full overlay panels. For 1/4 inch custom panel applications, replacement drawer handles are required. Part number 11926-4-BLK.

5. **Heavy duty, full extension drawer slides**

**BENEFIT:** Allows easy accessibility to contents in the back of drawers.

---

## ADDITIONAL FEATURES

1. Automatic (cycle) Defrost
2. Anchoring Device included
3. Interior light in each drawer
4. Vinyl clad steel cabinet (black)
5. Adjustable leveling legs
6. Available in black and stainless steel

---

## BENEFITS

Maintenance free defrosting.

Unit must be installed under a counter and must be anchored to prevent tipping if both drawers are open when full.

Automatically illuminates when drawers are opened.

Textured, rich look. Resistant to scratching, peeling and flaking.

More precise under the counter fit, durable factory installed.

Blends with all cabinet colors.