

Échelon™



CLR2060 CLEAR ICE MAKER

U
S
E
R
M
A
N
U
A
L



U-LINE
CORPORATION

U-LINE CORPORATION LIMITED WARRANTY

U-Line Corporation warrants each U-Line product to be free from defects in materials and workmanship for a period of one year from the date of purchase; and warrants the sealed system (consisting of the compressor, the condenser, the evaporator, the hot gas bypass valve, the dryer and the connecting tubing) in each U-Line product to be free from defects in materials and workmanship for a period of five years from the date of purchase. During the initial one-year warranty period for all U-Line products U-Line shall: (1) at U-Line's option, repair any product or replace any part of a product that breaches this warranty; and (2) for all Marine, RV and Domestic U-Line products sold and serviced in the United States (including Alaska and Hawaii) and Canada, U-Line shall cover the labor costs incurred in connection with the replacement of any defective part. During years two through five of the warranty period for the sealed system, U-Line shall: . (1) repair or replace any part of the sealed system that breaches this warranty; and (2) for all Marine, RV and Domestic U-Line products sold and serviced in the United States (including Alaska and Hawaii) and Canada, U-Line shall cover the labor costs incurred in connection with the replacement of any defective part of the sealed system. All other charges, including transportation charges for replacements under this warranty and labor costs not specifically covered by this warranty, shall be borne by you. This warranty is extended only to the original purchaser of the U-Line product. The Registration Card included with the product should be promptly completed by you and mailed back to U-Line.

The following are excluded from this limited warranty: installation charges; damages caused by disasters or acts of God, such as fire, floods, wind and lightning; damages incurred or resulting from shipping, improper installation, unauthorized modification, or misuse/abuse of the product; customer education calls; food loss/spoilage; door and water level adjustments (except during the first 90 days from the date of purchase) ; defrosting the product; adjusting the controls; door reversal; or cleaning the condenser.

If a product defect is discovered during the applicable warranty period, you must promptly notify either the dealer from whom you purchased the product or U-Line at P. O. Box 23220, Milwaukee, Wisconsin 53223 or at 414-354-0300. In no event shall such notification be received later than 30 days after the expiration of the applicable warranty period. U-Line may require that defective parts be returned, at your expense, to U-Line's factory in Milwaukee, Wisconsin, for inspection. Any action by you for breach of warranty must be commenced within one year after the expiration of the applicable warranty period.

This limited warranty is in lieu of any other warranty, express or implied, including, but not limited to any implied warranty of merchantability or fitness for a particular purpose; provided however, that to the extent required by law, implied warranties are included but do not extend beyond the duration of the express warranty first set forth above. U-Line's sole liability and your exclusive remedy under this warranty is set forth in the initial paragraph above. U-Line shall have no liability whatsoever for any incidental, consequential or special damages arising from the sale, use or installation of the product or from any other cause whatsoever, whether based on warranty (express or implied) or otherwise based on contract, tort or any other theory of liability.

Some states do not allow limitations on how long an implied warranty lasts or the exclusion or limitation of incidental or consequential damages, so the above limitations may not apply to you. This warranty gives you specific legal rights, and you may also have other rights which vary from state to state.

INTRODUCTION

Congratulations on your purchase of a U-Line CLR2060 Ice Maker. A pioneer in the field for nearly 40 years, U-Line is the world's number one manufacturer of built-in, under-counter ice making and specialty refrigeration products. U-Line dedicates 100% of its research and development to these products. The result: U-Line leads the market with innovation, design, depth of product line and performance.

U-Line also backs customers with a strong dealer network. U-Line's commitment to quality even extends to environmentally safe packaging. U-Line products are making life more convenient in homes, businesses and hotels around the world.

IMPORTANT

PLEASE READ all instructions completely before attempting to install or operate the unit. All Ice Makers require a connection to the water supply. Improper hook-up can result in substantial property damage! If you are unsure of your ability to safely connect the water supply to the unit, and the unit to the drain, consult a licensed plumber for assistance.

Once you have your unit installed, we suggest you keep this manual in a safe place for future reference. Should any problems occur, refer to the **TROUBLESHOOTING** section of this manual. This information will help you quickly identify a problem and get it remedied. In the event you require assistance, please contact the dealer where you purchased your unit.

PLEASE RECORD YOUR MODEL'S INFORMATION

Whenever you call to request information or service, you will need to know your model number and serial number. You can find this information on the serial plate located on the inside wall of your unit and on the warranty registration card.

WARRANTY REGISTRATION CARD

The package containing this manual also includes your warranty registration information. Warranty coverage begins at the time your ice maker was purchased.

NOTE

Complete and mail the Warranty Registration Card as soon as possible to validate the registration date.

User's Manual

If you do not return your Warranty Registration Card, U-Line will use the date of sale to the U-Line distributor as the first date of warranty for your new ice maker. Please also record the purchase date of your U-Line unit and your dealer's name, address and telephone number.

Model Number: _____
Serial Number: _____
Purchase Date: _____
Dealer Name: _____
Dealer Address: _____
Dealer Telephone: _____

Keep this manual and the sales receipt together in a safe place for further reference.

TABLE OF CONTENTS

INTRODUCTION.....	1
SAFETY PRECAUTIONS	3
INSTALLATION DIMENSIONS.....	5
DRAIN INSTALLATION.....	5
CONNECTING A DRAIN PUMP.....	8
SITE PREPARATION	9
CONNECTING THE WATER SUPPLY.....	11
LEVELING THE UNIT	13
REVERSING THE DOOR.....	14
CUSTOM DOOR PANELS	17
BUILT-IN INSTALLATION.....	19
INITIAL START-UP.....	20
NORMAL OPERATION	21
OUTDOOR USE	21
MAINTENANCE.....	22
STORAGE, VACATION AND MOVING	27
TROUBLESHOOTING	29
IF SERVICE IS REQUIRED	31

SAFETY PRECAUTIONS

Do not attempt to install or operate your unit until you have read the safety precautions in this manual. Safety items throughout this manual are labeled with a Danger, Warning or Caution based on the risk type.

DEFINITIONS



Danger means that failure to follow this safety statement may result in severe personal injury or death.



Warning means that failure to follow this safety statement may result in extensive product damage, serious personal injury, or death.

CAUTION

Caution means that failure to follow this safety statement may result in minor or moderate personal injury, property or equipment damage.

User's Manual

GENERAL PRECAUTIONS



RISK OF CHILD ENTRAPMENT. Before you throw away your old refrigerator or freezer, take off the doors and leave shelves in place so that children may not easily climb inside.



- Never attempt to repair or perform maintenance on the unit until the electricity has been disconnected.
- Altering, cutting of power cord, removal of power cord, removal of power plug, or direct wiring can cause serious injury, fire and/or loss of property and/or life and will void the warranty.

CAUTION

- Do not lift unit by door handle.
- Never use an ice pick or other sharp instrument to help speed up defrosting. These instruments can puncture the inner lining or damage cooling unit.
- Failure to clean the condenser every three months can cause the unit to malfunction. This could void the warranty.
- Never install the unit behind closed doors. Be sure front grille is free of obstruction. Obstructing free air flow can cause the unit to malfunction, and may void the warranty.

CAUTION

- **DO NOT** use any type of heater to defrost. Using a heater to speed up defrosting can cause personal injury and damage to the inner lining.
- Use only genuine U-Line replacement parts. Imitation parts can reduce ice rate, cause water to overflow from ice maker mold, damage the unit, and may void the warranty.

INSTALLATION DIMENSIONS

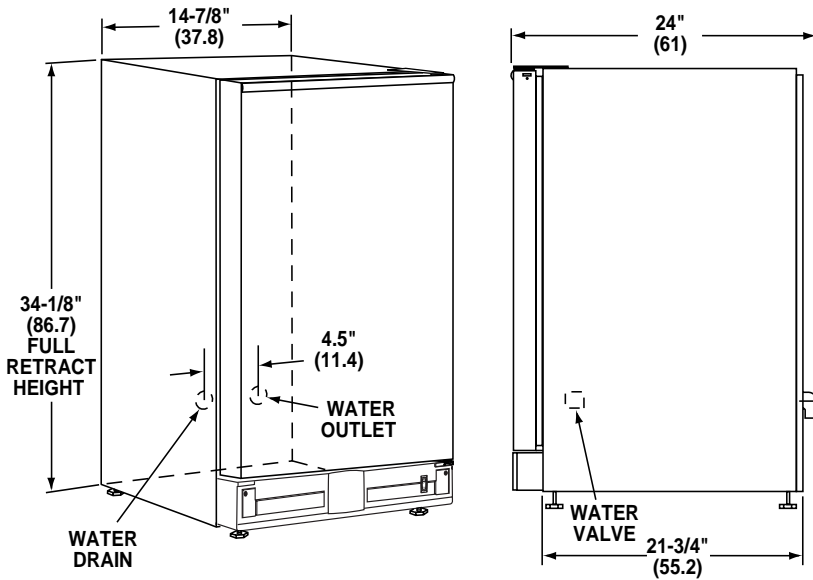

UL202

Figure 1

DRAIN INSTALLATION

IMPORTANT

PLEASE READ all instructions completely before attempting to install or operate the unit. All Ice Makers require a connection to the water supply and improper hook-up can result in substantial property damage! All water and drain connections **MUST BE** made by a licensed/qualified plumbing contractor. Failure to follow recommendations and instructions may result in damage and/or harm.



CAUTION

Plumbing installation must observe all state and local codes. All water and drain connections **MUST BE** made by a licensed/qualified plumbing contractor. Failure to follow recommendations and instructions may result in damage and/or harm.

The CLR2060 can be installed using a gravity drain or can use a factory installed or equivalent drain pump.

User's Manual

Follow these guidelines when installing drain lines to prevent water from flowing back into the ice maker storage bin and/or potentially flowing onto the floor causing water damage:

Gravity Drain

- Drain lines must have a 5/8 inch inside diameter.
- Drain lines must have a 1 inch drop per 48 inches of run (1/4 inch per foot) and must not create traps.
- The floor drain must be large enough to accommodate drainage from all drains.
- Insulate the bin drain line to prevent condensation.

CLR2060 With Factory Installed Drain Pump

NOTE

Before installing your U-Line CLR2060 With Factory Installed Pump, it is extremely important to check and test all hose connections at the drain pump. There is a possibility that hose connections may have loosened during shipment.



WARNING

To prevent accidental electrocution, make certain that the floor surfaces surrounding the unit are dry whenever power is removed from, or applied to the unit.

1. Make certain the unit is not plugged into an electrical outlet.
2. Carefully push the power cord grommet through the hole in the back panel.

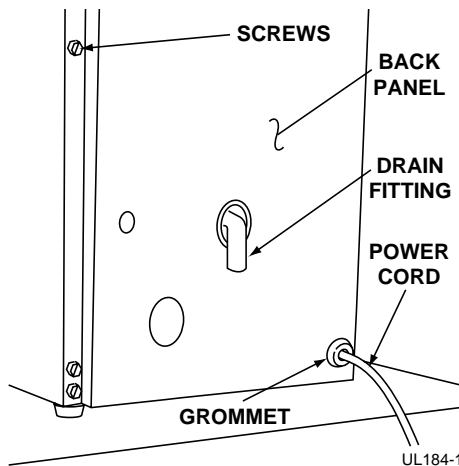

3. Remove 12 screws and back panel.
4. Check that the clamps and hose connections are tight at the following areas:
 - Discharge tube (A)
 - Drain tube (B)
 - Vent tube (C)

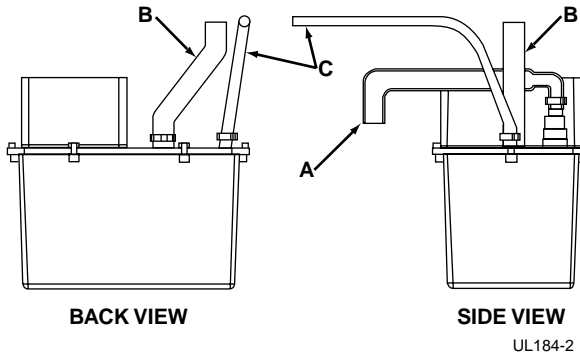

5. Place a suitable container beneath the pump's discharge tube. (The bucket must be able to hold a minimum of one gallon.)



WARNING

Back panel serves as a guard. **DO NOT** put your hands inside the ice maker cabinet or attempt to touch any components except the discharge tube during testing. Failure to follow this warning could result in serious personal injury or death.

6. Plug the ice maker power cord into a properly grounded, polarized electrical outlet.
7. Verify pump operation by pouring one gallon of water into the ice storage bin of the ice maker. The pump should energize and pump the water into the container.
8. At this time, verify that all tube and clamp connections are tight and leak free.
9. Unplug unit power cord from electrical outlet.
10. Leave back panel off for water supply line installation.
11. Continue to the next step in the installation process, SITE PREPARATION.

CONNECTING A DRAIN PUMP

If a gravity drain connection is not available, and you have not purchased the CLR2060 with factory installed pump, we strongly recommend the use of the U-Line P60 drain pump. The U-Line P60 drain pump is available through your Dealer, or direct from U-Line with complete installation instructions. If a pump other than the U-Line P60 drain pump is to be used, it must meet the following specifications:

- It must be UL listed and have a UL listed, 120 VAC, 3-wire grounded power cord.
- It must have overall maximum outside dimensions of 8-3/4" wide x 5-3/4" deep x 7-3/4" high.
- It must have a minimum flow rate of 15 gallons per hour at 10 feet of lift.
- It must have a sealed sump which does not allow water leakage in the case of a power outage, restricted drain or pump failure.
- It must have a check valve in the discharge line to prevent waste water return to the pump.
- It must have an overflow protection control which will shut off power to the ice maker in the event of a pump failure.
- It must have an operating temperature range of 50°F to 110°F (10°C to 40°C).



CAUTION

In the event of a power outage, restricted drain or pump failure, the failure to use the U-Line P60 drain pump or a pump with the above listed specifications, could result in substantial water leakage and pooling with severe and costly water damage and related consequential damages and harm.

SITE PREPARATION

1. Position the unit on a flat, level surface, capable of supporting the entire weight of the unit. Remember that the unit will be significantly heavier once it is fully loaded.

IMPORTANT

It is extremely important that the unit is level. If it is not level, the ice mold will not fill evenly. This can cause a reduction in ice rate, uneven sized cubes or water spilling into the storage area which will cause the ice in the bin to melt prematurely. Remember that floors near drains have a tendency to slope towards the drain.

2. The surrounding air temperature must be at least 50°F (10°C) but must not exceed 110°F (40°C).
3. The unit must not be located near heat-generating equipment or in direct sunlight.
4. The unit must be located to allow clearance for water, drain and electrical connections in the rear of the ice maker.
5. Connect the unit to a grounded and polarized 115 VAC, 60 Hz, 15A circuit (normal household current).

DANGER



ELECTROCUTION HAZARD!

Electrical Grounding Required. This appliance is equipped with a three prong (grounding) polarized plug for your protection against possible shock hazards.

- **NEVER** remove the round grounding prong from the plug.
- **NEVER** use a two-prong grounding adapter.
- **NEVER** use an extension cord to connect power to the unit.

Where a two-prong wall receptacle is encountered or a longer power cord is required, contact a qualified electrician to have it replaced in accordance with applicable electrical codes.

User's Manual

NOTE

The door of the unit may be mounted on either side of the cabinet (see **REVERSING THE DOOR**). All U-Line units (except Stainless Steel models) have a zero clearance for the door to open (see Figure 2). See **BUILTIN INSTALLATION** for additional clearance requirements.

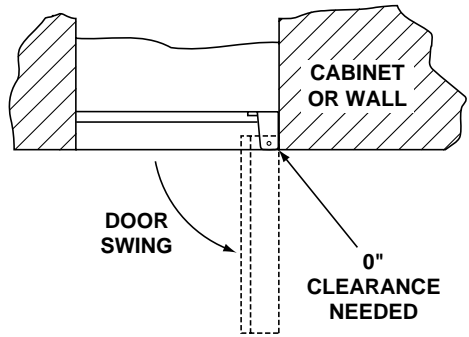

UL124A

Figure 2

NOTE

Stainless Steel models require a minimum of 2-1/2" door clearance.

6. Install and connect the water supply line. See **CONNECTING THE WATER SUPPLY** for installation requirements.
7. Position the unit to allow free air flow through the front grille (see Figure 3).

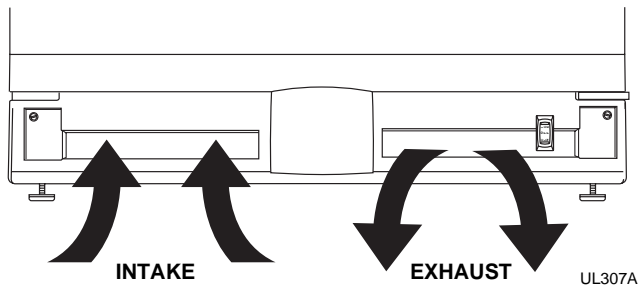

UL307A

Figure 3

8. Be sure to install Anti-tip brackets. Follow the instructions provided with the Anti-Tip Bracket Kit.
9. Wipe out inside of unit with a damp cloth.

CONNECTING THE WATER SUPPLY

When connecting the water supply, follow these guidelines:

- Review the local plumbing codes before you install the unit.
 - In most instances, the cold water supply will come from the basement through a hole in the floor.
 - The water pressure should be between 15 and 150 psi.
 - Install a shut-off valve in the 1/4 inch supply line.
 - Connect sufficient tubing to the unit to allow the unit to be moved for cleaning and servicing. However, make certain that the tubing is not pinched or damaged during installation.
 - U-Line recommends the use of copper tubing for installation.
1. Remove grille from front of the unit (see Figure 4). Refer to CONDENSER CLEANING.
 2. Remove the back panel to ease water line connection.
 3. Install the 1/4 inch copper water line, from the main water source. The water line is inserted through the hole in the rear of the unit, through a clip on the sidewall to connect to the solenoid valve in the front (see Figure 5).

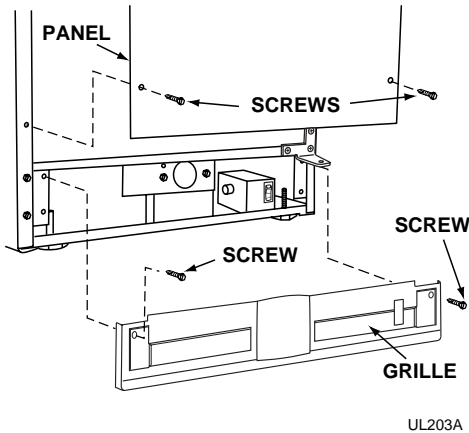

Figure 4

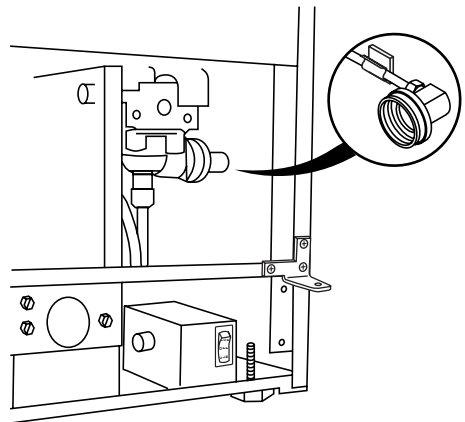

Figure 5

UL401

User's Manual

4. Locate the compression fitting and ferrule packed in the unit. Slide the compression fitting and ferrule over the 1/4 inch water supply line. Do not use thread sealing compound or tape. Using two wrenches, tighten the compression fitting on the supply line (see Figure 6).

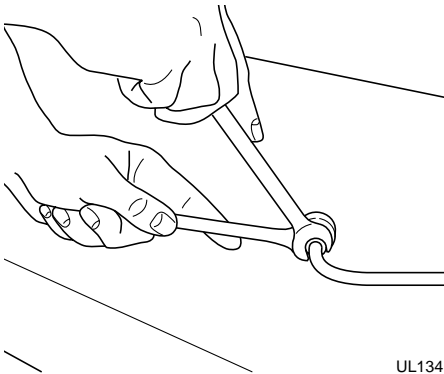

Figure 6

UL134

5. Carefully bend the water supply line into position and connect the line to the solenoid valve (see Figures 7 and 8). Avoid kinking the water supply line.

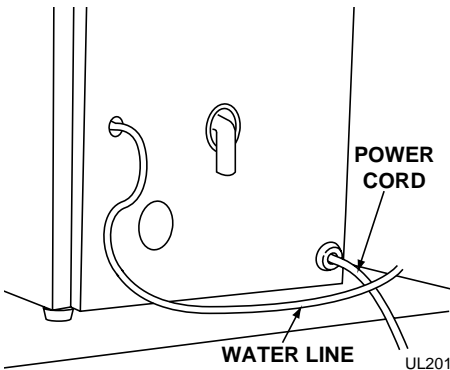
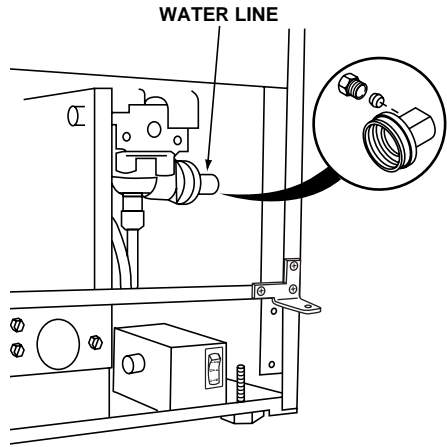

Figure 7

UL201



UL402

Figure 8

6. For recessed installations, allow extra water supply line length to provide slack for easy removal from the recessed area (see Figure 9). This will also safeguard against kinking the line.

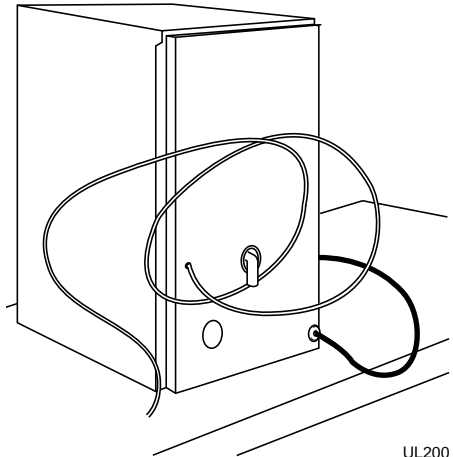

UL200

Figure 9

NOTE

After completing the installation, turn on the water and recheck water and drain connection for leaks. Apply additional tightening if needed. Do NOT use thread sealing compound or tape.

NOTE

Route the water supply line through the clip on the sidewall of the unit in such a way as to prevent the line from coming in contact with any internal components other than the solenoid valve (see Figure 5). Normal operation creates some vibration. A water supply line contacting an internal component or cabinet wall may cause excessive noise during operation or damage to the line.

7. Re-install back panel and grommet.
8. Install access panel.
9. Install the grille. See CONDENSER CLEANING.
10. Plug in the power cord.
11. Gently push the unit into position. If desired the unit may be recessed into cabinet or wall.
12. Allow at least 1-1/2 inches clearance behind the unit for electrical, water supply and drain connections.

LEVELING THE UNIT

NOTE

It is extremely important that the unit is level. If it is not level, the ice mold will not fill evenly. This can cause a reduction in ice rate, uneven sized cubes or water spilling into the storage area which will cause the ice in the bin to melt prematurely. Remember that floors near drains have a tendency to slope towards the drain.

1. Use a level to check the levelness of the ice maker from front to back and from side to side (see Figure 10).
2. If the ice maker is not level, adjust the feet on the corners of the unit as necessary (see Figure 11).

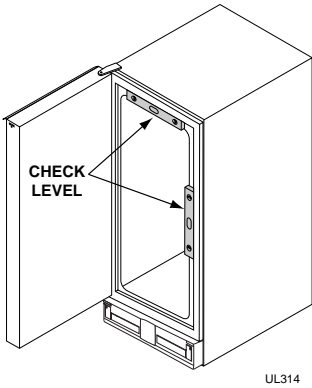

Figure 10

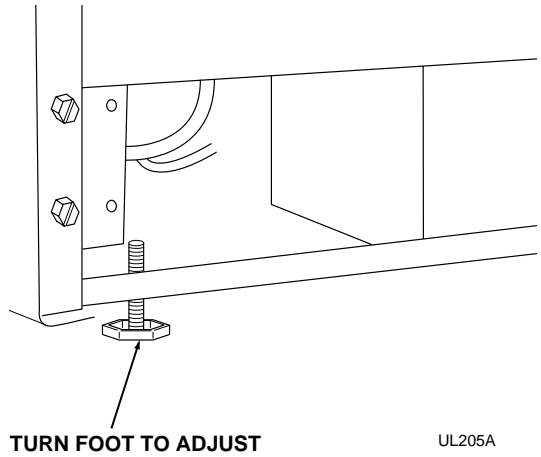

Figure 11

3. Check the levelness after each adjustment and repeat the previous steps until the unit is level.

REVERSING THE DOOR

All U-Line units (except Stainless Steel models) may be left or right hand opening. The door opening is easily reversed by moving the hinge hardware to the opposite side (see Figure 12). To reverse the door:

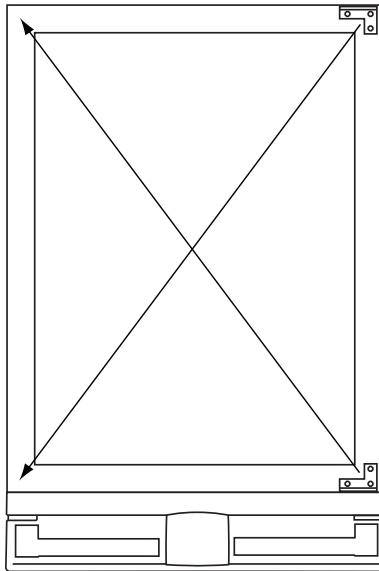

Figure 12

1. Remove top hinge screw pin (7/64" Allen wrench) from cabinet (see Figure 13). Remove door by tilting forward and lifting off bottom hinge pin.
3. Remove top hinge (3 screws), reinstall hinge screw pin, and remount on opposite side **BOTTOM** (see Figure 15).

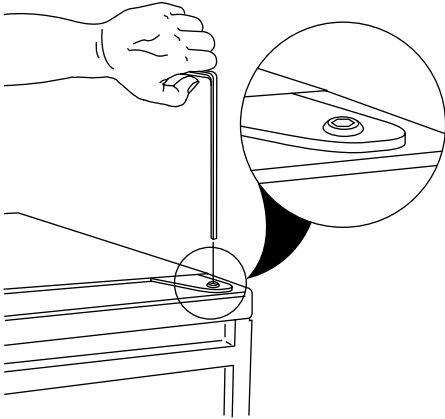

Figure 13

UL310

2. Remove plastic screw plugs (3 each, top and bottom) from new hinge location. Do not discard (see Figure 14).

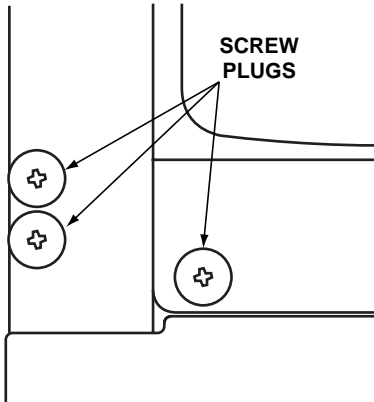

Figure 14

UL308

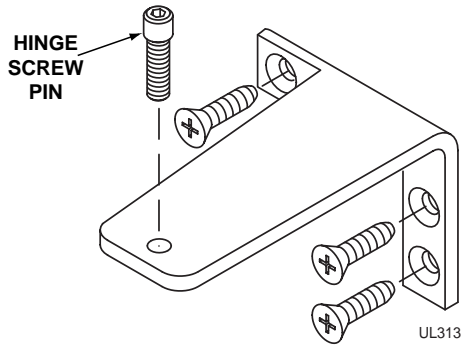

Figure 15

4. Remove the two door closer inserts from the existing bottom hinge and install as shown on the new bottom hinge (see Figure 16).

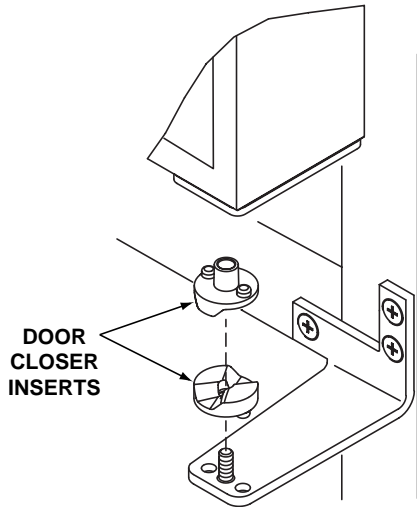
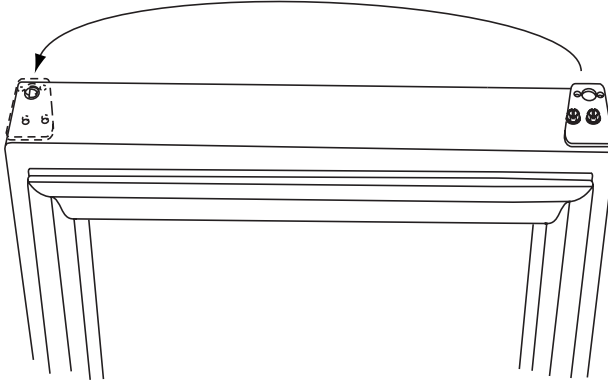

Figure 16

UL312

User's Manual

5. Remove existing bottom hinge (3 screws) and remount on opposite side TOP. Remove hinge screw pin.
6. With bottom of door facing up, remove pivot plate (2 screws), flip over, and remount on opposite side of door (see Figure 17).



UL319

Figure 17

7. Holding door upright with top of door tilted forward, place hole of door pivot plate on bottom hinge screw pin (see Figure 18).
8. Tilt top of door into position in top hinge and install top hinge screw pin.
9. Install plastic screw plugs removed in Step 2 in old hinge holes (3 each, top and bottom).

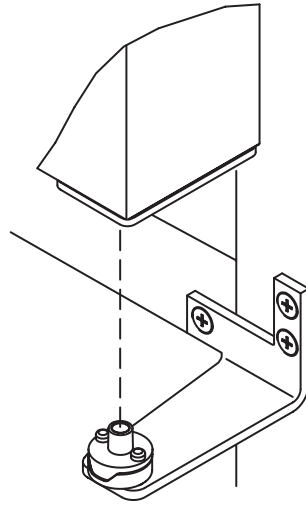

UL312A

Figure 18

CUSTOM DOOR PANELS

Two types of custom door panels can be installed on your U-Line unit to harmonize with or accent the surrounding decor.

FULL OVERLAY DOOR PANEL

A full overlay door panel completely covers the door frame and handle to give a built-in appearance. See your U-Line dealer for the optional Full Overlay Door Panel Kit which contains the Panel Preparation Document for building and installing a full overlay panel. See Table 1 and Figure 19 for full overlay door panel dimensions.

Table 1. Full Overlay Panel Dimensions

Model	A	B
CLR2060	29-7/8"	14-3/4"

CUSTOM INSERT DOOR PANEL

A custom door panel can be inserted into the door frame to better match the surrounding decor. Custom door panels can be flat or raised, as long as the maximum panel thickness where inserted into the door reveal (channel) is 1/4" thick. For raised panels, the depth of the reveal is 1/4" on all four sides. See Table 2 and Figure 19 for custom door panel insert dimensions.

Table 2. Custom Insert Door Panel Dimensions

Model	A	B
2015 Series	28-5/32"	14-1/32"
2075 Series	28-5/32"	23-1/32"

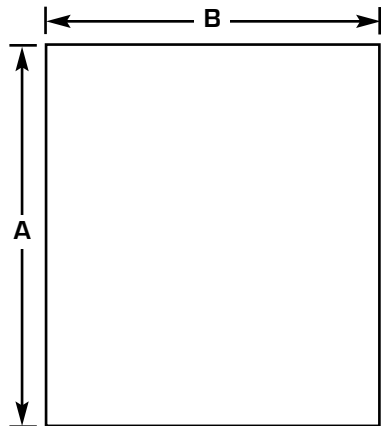

Figure 19

IMPORTANT

The door panel insert must not weigh more than 20 lbs.

User's Manual

Install the insert as follows:



WARNING

Insert edges may be SHARP! Use care when installing.

1. Remove top hinge screw pin (7/64" Allen wrench, see Figure 20). Remove door by tilting forward and lifting off bottom hinge pin.
2. Remove two outside screws holding door handle. Slightly separate door handle from door (see Figure 21).
3. Pull door gasket out of groove (top edge of door only). Start in the middle and pull outward, moving toward the edge (see Figure 22). This may take some force. Do not remove the three screws behind gasket.
4. Pull handle up and off.
5. Slide custom door panel insert into 1/4 inch channel in door front.
6. Holding door gasket out of the way, replace handle on door making sure it is seated properly on insert and that screw holes line up.
7. Install two small screws removed in step 2.
8. Starting at the corners and working inward, push door gasket into place on door.
9. Place door on bottom hinge pin and install upper hinge screw.

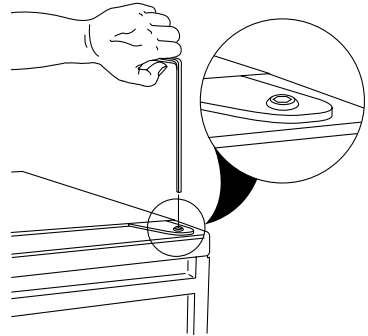

UL310

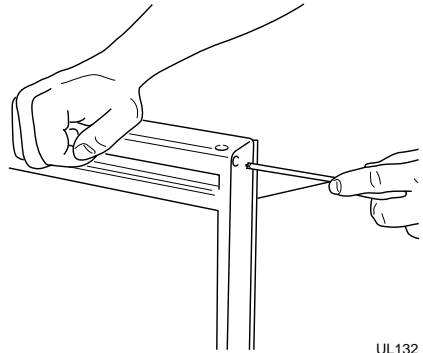

UL132

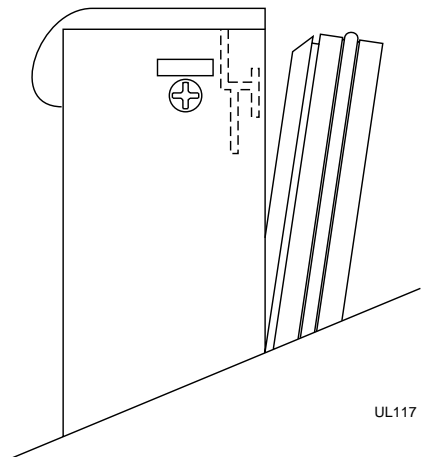

UL117

BUILT-IN INSTALLATION

Your U-Line product has been designed for either free-standing or built-in installation. When built-in, your U-Line product does not require additional air space for top, sides or rear. However, the front grille must NOT be obstructed.



CAUTION

Do not install unit behind closed doors.

Table 3. Built-in Cabinet Dimensions

Model	Unit Dimensions		
	Width	Height	Depth
CLR2060	14-15/16"	34-1/8"	24"

NOTE

To ease unit installation and removal, increase the above measurements. It is recommended that the cabinet rough opening dimensions be increased by at least 1/4" over the dimensions given for your unit. The unit must be located to allow clearance for water, drain and electrical connections in the rear of the ice maker.

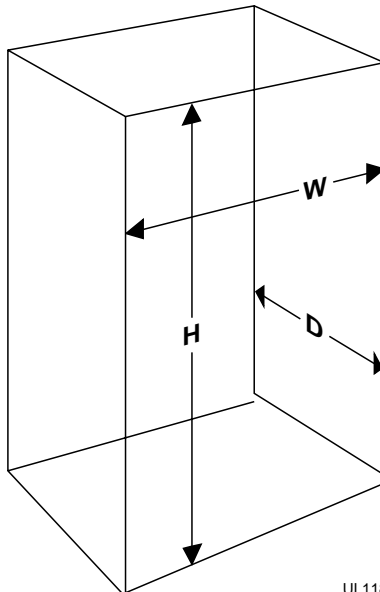

UL118

Figure 23

INITIAL START-UP

Once installation and leveling is complete, the unit is ready for initial start-up and operation. Your unit is shipped in the OFF position, however, you may turn it ON/OFF using the cycle selector switch located in the grille (see Figure 24).

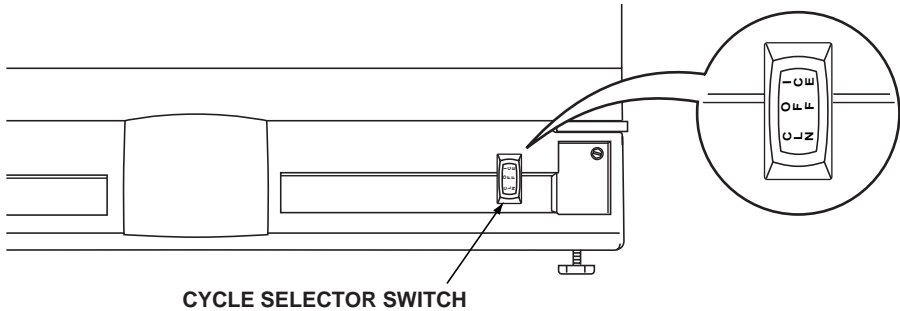

UL316B

Figure 24

1. Plug the appliance cord into a 115V polarized and grounded electrical outlet.
2. Open the water supply valve in the main water source.
3. Put the cycle selector switch in the ICE position (press the switch to the right). The water fill valve will energize and fill the water reservoir. The water fill valve shuts off after 180 seconds. The compressor begins to operate and water flows over the evaporator assembly (ice cube tray).
4. Upon initial start-up, water flow over the evaporator may be uneven. This may cause uneven sized cubes or water spilling into the ice storage bin. This is a normal situation and will correct itself within the first twenty-four hours of operation. After the initial start-up period, the water will cascade evenly over the evaporator.

IMPORTANT

It is possible that dirt or scale will dislodge in the water line. Always throw away all ice cubes made during the first two to three hours of operation.

NORMAL OPERATION

The ice maker is designed to make clear ice from most water sources on a consistent basis. Water is constantly circulated over the evaporator assembly. As the water freezes, gravity causes any sediment to drop into the water trough and not become imbedded in the ice. This gives a clearer ice cube with a low mineral content.

When the ice reaches the desired thickness, it falls off the evaporator and into the storage bin. The cycle is then repeated. When the level of ice reaches the top of the storage bin the unit shuts off. As the ice level in the bin drops the unit will automatically restart to keep the bin full.

Your unit's ice production rate may vary depending on many considerations. Ambient air temperatures, water temperatures, condenser cleanliness and ice-maker cleanliness are all contributing factors to how quickly the unit produces ice.

Certain sounds are normal during the unit's operation. You may hear the compressor or fan motor, the water valve, the water circulation pump or ice dropping into the ice storage bin.

OUTDOOR USE

Some CLR2060 models are designed to operate outdoors. Special considerations include the following:

- For best performance, keep the unit out of direct sunlight.
- Turn the unit OFF and dispose of any ice cubes if the unit will not be used for 5 days or more. Prop door open to allow for air circulation and prevent mold and mildew.
- If the ambient temperature is expected to drop below 45°F, drain all water from the unit to prevent freezing damage not covered by the warranty.
- High ambient temperatures (110°F or higher) may reduce the unit's ability to reach low temperatures and may also reduce the ice production rate.

MAINTENANCE

Periodic cleaning and proper maintenance will ensure efficiency, top performance, and long life. The maintenance intervals listed are based on normal conditions. You may want to shorten the intervals if you have pets, the unit is used outdoors, or other special considerations.

EXTERIOR CLEANING — AS REQUIRED

The door, grille and cabinet may be cleaned with a mild detergent and warm water solution. Do not use solvent based or abrasive cleaners. Use a soft sponge and rinse with clean water. Wipe with a soft, clean towel to prevent water spotting.

Stainless steel models can be cleaned with kitchen cleaner and a damp cloth. Never use abrasive cleaning agents.



CAUTION

Stainless steel models exposed to chlorine gas and moisture, such as areas with spas or swimming pools, may have some discoloration of the stainless steel. Discoloration from chlorine gas is normal. Follow exterior cleaning instructions.

INTERIOR CLEANING — AS REQUIRED

1. Disconnect power to the ice maker.
2. Open the door and remove any ice from the storage bin.
3. Wipe down the interior and storage bin with a solution of non-abrasive mild soap or detergent and warm water. Rinse with clean water.
4. Sanitize the bin with a solution of 1 tablespoon of bleach in 1 gallon of warm water. Rinse thoroughly with clean water.
5. Check that all drain connections are in place.
6. Reconnect power to the unit.



WARNING

- **DO NOT** use solvent cleaning agents or abrasives on the interior. These cleansers may transmit taste to the ice cubes, or damage or discolor the interior.
- **DO NOT** use any cleaner inside the ice maker compartment other than U-Line Ice Machine Cleaner. Other cleaners may affect ice quality or damage the unit not covered under warranty. See **AUTOMATIC CLEAN CYCLE** for more information.

CONDENSER CLEANING — EVERY 3 MONTHS



WARNING



Disconnect electric power to the ice maker before cleaning the condenser.

To remove and replace the grille for access to the condenser fins follow this procedure:

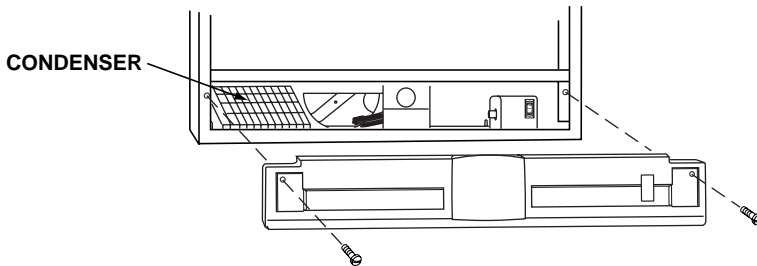

UL317A

Figure 25

1. Remove the screws at each end of the grille.
2. Remove the grille.

User's Manual



WARNING

DO NOT touch the condenser fins. The condenser fins are **SHARP** and can be easily damaged.



CAUTION

DO NOT use any type of cleaner on the condenser unit.

3. Clean the condenser coil using a brush or vacuum cleaner. Do not touch.
4. Position the grille to align the screw holes with the cabinet.
5. Insert the grille screws and tighten being careful not to overtighten.

SELF CLEANING CYCLE — EVERY 6 MONTHS

To maintain operational efficiency, clean the unit every six months (depending on water conditions more or less frequent cleaning may be necessary). If the ice maker requires more frequent cleaning, consult a qualified plumber to test the water quality and recommend appropriate treatment.



WARNING

Wear rubber gloves and safety goggles and/or face shield when handling Ice Machine Cleaner.



CAUTION

Use only U-Line Ice Machine Cleaner (part number 41978). It is a violation of Federal law to use this solution in a manner inconsistent with its labeling. Use of any other cleaner can ruin the finish of the evaporator and will void the warranty. Read and understand all labels printed on the package before use.

Ice machine cleaner is used to remove lime scale and other mineral deposits. Refer to the following steps for mineral deposit removal.



CAUTION

Never use anything to force ice from the evaporator. Damage may result.

1. Set the cycle selector switch to OFF and allow the ice to melt off of the evaporator.
2. Remove all ice from the storage bin.
3. Remove inside front cover (see Figure 26).
4. Remove the overflow tube by lifting it up while using a slight back and forth motion to loosen it from the drain hole (see Figure 27). The water in the reservoir will flow down the drain.
5. Replace the overflow tube after all of the water has drained from the reservoir.
6. Move the cycle selector switch to the CLN position.
7. When water begins to flow over the evaporator (approximately 3 minutes), add one package of U-Line Ice Machine cleaner to the water reservoir.
8. Reinstall inside front cover.

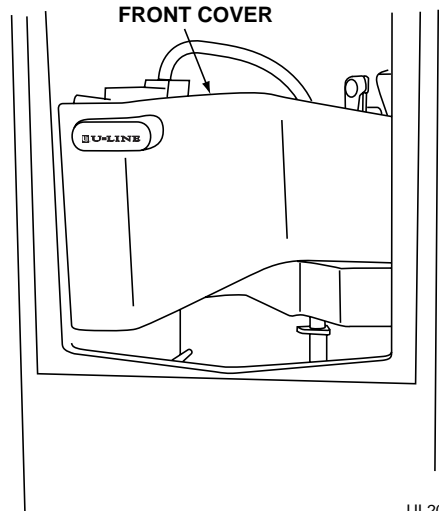

UL208

Figure 26

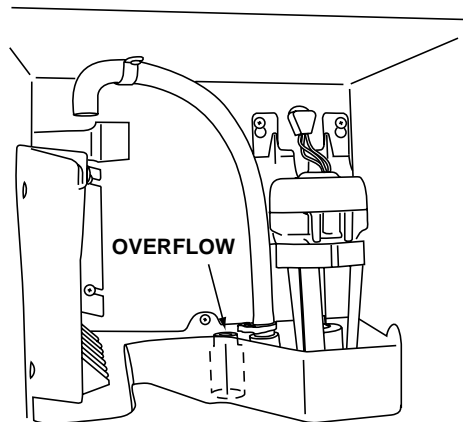

UL209

Figure 27

User's Manual

9. When the self-cleaning process stops (approximately 45 minutes) it may be desirable to clean the storage bin at this time (see **INTERIOR CLEANING**).
10. Move the cycle selector switch to the ICE position to resume ice production.

INLET SCREEN CLEANING — EVERY YEAR

The solenoid valve inlet screen must be cleaned at least once each year as follows:

1. Shut off the water at the water supply valve.
2. Remove front access panel to expose water solenoid valve.
3. Remove the entire hose connector from the solenoid valve.
4. Use a tooth brush to clean sediment from the inlet screen (see Figure 28). **DO NOT** remove the screen.
5. Attach the hose connector to the solenoid valve. Tighten connector securely with a pliers. Open the water supply valve and check for leakage at the hose connector.

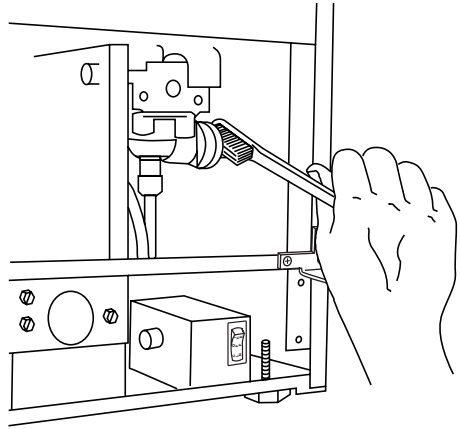

UL403

Figure 28

STORAGE, VACATION AND MOVING

If the unit is to be stored, moved or not used for extended periods, it will be necessary to drain the system of water.



WARNING



Electrical Shock Hazard. Disconnect power before servicing. Before operating replace all panels. Failure to do so can result in death or electrical shock.

1. Disconnect power from the unit.
2. Remove ice from the storage bin.
3. Shut off water supply at the main water source.
4. Remove grille (2 screws).
5. Remove the front access panel (2 screws) (see Figure 4).
6. Disconnect the inlet and outlet lines to the water valve and allow them to drain (see Figure 29).

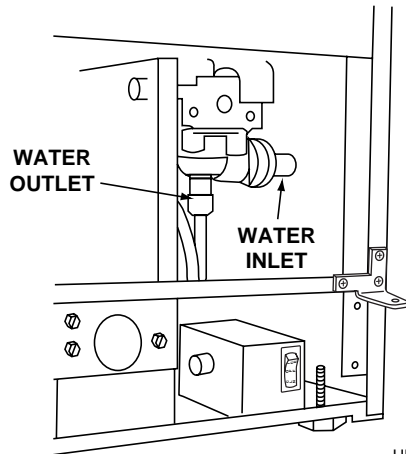

UL404

Figure 29



WARNING

If the ambient temperature is expected to drop below 40°F, drain all water from the unit to prevent freezing damage not covered by the warranty.

NOTE

The use of anti-freeze or other products of this nature is not necessary and is not recommended.

User's Manual

7. Reconnect inlet and outlet lines to the water valve.
8. Replace front access panel.
9. Replace grille.
10. Drain water from the water trough and drain line by removing the overflow tube (see Figure 27).
11. Clean the ice maker and storage bin before next use.
12. Prop door open to allow for air circulation and prevent mold and mildew.

TROUBLESHOOTING

BEFORE CALLING FOR SERVICE

If the unit appears to be malfunctioning, read through NORMAL OPERATION first. If the problem persists, check the TROUBLESHOOTING GUIDE. Locate the problem in the guide and refer to the cause and its remedy before calling for service. The problem could be something very simple which can be solved without a service call.

TROUBLESHOOTING GUIDE



ELECTROCUTION HAZARD

NEVER attempt to repair or perform maintenance on the unit until the main electrical power has been disconnected.

Troubleshooting — What to check when problems occur

Problem	Possible Cause	Remedy
The unit does not operate.	No electrical power to the unit.	Make sure power cord is plugged in. Check for blown fuse or tripped circuit breaker.
	Cycle selector switch set improperly.	Make sure cycle selector switch is set to ICE.
	Low air temperature around unit.	Surrounding air temperature must be at least 50°F (10°C).
Unit runs but no ice is produced.	No water being supplied to the unit.	Check to see that water is connected and turned on to the unit.
Unit runs but produces very little ice.	Dirty condenser coils.	Clean the condenser. See MAINTENANCE.
	High air temperature around unit.	Surrounding air temperature of over 90°F (32°C). Low ice production at high temperatures is normal.

User's Manual

Problem	Possible Cause	Remedy
Unit runs but produces very little ice. (continued)	Scale and mineral buildup in unit.	Clean unit. See MAINTENANCE.
	Inadequate airflow at the front of the unit.	Remove items blocking airflow.
Ice is slow to release or does not release from the evaporator.	Ice-making system is dirty.	Run unit through automatic clean cycle. See MAINTENANCE.
	Unit is not level.	See LEVELING THE UNIT.
	Low air temperature around unit.	Surrounding air temperature must be at least 50°F (10°C).
Poor ice quality. (soft or unclear)	Poor incoming water quality.	Consult a qualified plumber to test the water quality and recommend appropriate treatment.
	Ice-making system is dirty.	Run unit through automatic clean cycle. See MAINTENANCE.
Unit produces shallow or incomplete cubes, or the ice fill pattern on the evaporator is incomplete.	Low water level.	Check to see that overflow tube is fully seated.
	Hot incoming water.	Connect the unit to a cold water supply. See INSTALLATION.
	Incorrect incoming water pressure.	Water pressure must be 15-150 psi.
	Unit is not level.	See LEVELING THE UNIT.

Problem	Possible Cause	Remedy
Water leaking from under the unit.	Supply line leaking.	Check to see that water inlet line is attached to inlet valve properly. See CONNECTING THE WATER SUPPLY.
	Fill tube leaking.	Check connection at water valve outlet.
	Bin drain leaking.	Check integrity of bin drain hose and clamp.
Ice storage bin full of water.	Obstructed drain.	Check to see that storage bin drain opening is free from obstruction and debris.

IF SERVICE IS REQUIRED

If the need for service arises, contact the dealer from whom the unit was purchased. State the Model Number and Serial Number and explain the problem. The Model and Serial Number plate is located inside unit at upper right hand corner.



U-LINE
CORPORATION

P. O. Box 245040

Milwaukee, WI 53224-9540

Phone: 414.354.0300

Fax: 414.354.7905

www.u-line.com