



Échelon™ Series

Installation Guide



CLR2060 — Clear Ice Maker

www.U-LineService.com

Phone (414) 354-0300 • FAX (414) 354-7905
Service & Parts Tech Lines Phone (800) 779-2547 • FAX (414) 354-5696
OnlineService@U-Line.com

©2005 U-Line Corporation
02/2005

Contents

Cut-Out Dimensions 4
 Product Dimensions 4
 Door Swing/Clearances Information 4
 Reversing the Door..... 5
 Other Site Requirements 6
 Side-By-Side Installation Instructions 6
 Custom 1/4" Door Panel Insert 7
 Full Overlay Door Panel 8
 Checking Door Alignment 11
 Adjusting Door Alignment 11
 Drain Connection 12
 Water Supply Connection 15
 Electrical Specifications 16
 Leveling Information 16
 Installation Tip 17
 Installation of the CLR2060 17
 Installation Troubleshooting 18
 Initial Start-Up 18
 Start-Up Troubleshooting 19
 Service Information 20

1 Follow Safety Precautions

IMPORTANT

PLEASE READ all instructions completely before attempting to install or operate the unit.

- This unit requires connection to the water supply. Improper hook-up can result in substantial property damage! If you are unsure of your ability to safely connect the water supply to the unit, consult a licensed plumber for assistance.
- This unit requires connection to a drain. Improper connection can result in substantial property damage! If you are unsure of your ability to safely connect the unit to a drain, consult a licensed plumber for assistance.
- This unit requires connection to a grounded (three-prong), polarized receptacle that has been placed by a qualified electrician in accordance with applicable electrical codes.

Safety Alert Definitions

Safety items throughout this guide are labeled with a Danger, Warning or Caution based on the risk type:

⚠ DANGER

Danger means that failure to follow this safety statement will result in severe personal injury or death.

⚠ WARNING

Warning means that failure to follow this safety statement could result in serious personal injury, or death.

⚠ CAUTION

Caution means that failure to follow this safety statement may result in minor or moderate personal injury, property or equipment damage.

General Precautions

Use this appliance for its intended purpose only and follow these general precautions along with those listed throughout this guide:

WARNING

SHOCK HAZARD — Electrical Grounding Required.

- **Keep the unit unplugged throughout installation except during testing.**
- **Never remove the round grounding prong from the plug and never use a two-prong grounding adapter.**
- **Never use an extension cord to connect power to the unit.**
- **Always keep your working area dry.**

CAUTION

- Use care when moving and handling the unit. Use gloves to prevent personal injury from sharp edges.
- Do not lift the unit by the door or door handle.
- Do not install the unit behind closed doors or in any way that would obstruct airflow to the front grille, which may cause the unit to malfunction.

2 Inspect and Plan

You have received a carton containing your CLR2060 Clear Ice Maker with a package inside containing a User Manual, a Product Registration Card and water connection parts. Complete and mail the Product Registration Card or register online at www.U-LineService.com. Once your unit is installed, keep the User Manual and this Installation Guide in a safe place for future reference.

Your unit is Black, White or Stainless Steel. Black and White units have a reversible door with a slightly contoured handle across the top. They come with a flush mounted door panel that, when removed, will accept a custom 1/4-inch thick door panel or a 3/4-inch thick full overlay door panel. Stainless Steel units are covered with a protective coating and have been ordered left- or right-hand hinged. The Stainless doors are not reversible and do not accept custom panels. CLR2060 Clear Ice Makers may be ordered with a factory-installed drain pump. Please carefully follow the directions that apply to your unit and your intended design.

Tools/Materials Required

- 7/64" Allen wrench
- Screwdrivers — slotted and Phillips head
- 1/4-inch OD copper tubing and shut-off valve for water supply line
- 5/8-inch ID drain line
- P60 Drain Pump (if required and not already factory installed, see **Page 12**)
- 1/4-inch thick door panel material and cutting tools (Black or White units)
- Full Overlay Door Panel Kit (part number U-OL2015B — Black or part number U-OL2015W — White), 3/4-inch door panel overlay, cutting tools, drill and bits (Black or White units)

Inspection

Unwrap and inspect the unit on a flat, level surface capable of supporting its entire weight.

3 Prepare Site

Your U-Line product has been designed for either free-standing or built-in installation. When built-in, your unit does not require additional air space for top, sides or rear. However, the front grille must NOT be obstructed and clearance is required for water, drain and electrical connections in the rear.

Note: Unit can NOT be installed behind a closed cabinet door.

Cut-Out Dimensions

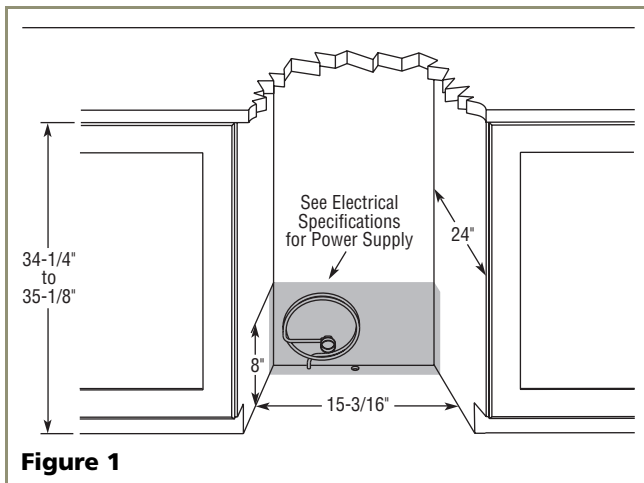

Follow the cut-out drawing in **Figure 1**. The 15-3/16" width allows 1/4" for ease in installation and removal of the unit. The 24" depth is the counter depth in most installations. The unit is 24" deep including the handle on Black and White models and 24" deep including the door and *not* the handle on Stainless Steel models (see **Figure 2**).

IMPORTANT

If you would like to align the face of the unit with other adjacent cabinet doors in certain installations, you may need to alter the wall just behind the drain connection on the unit to accommodate the drain. The actual amount of alteration will be determined by your actual drain connection components.

Product Dimensions

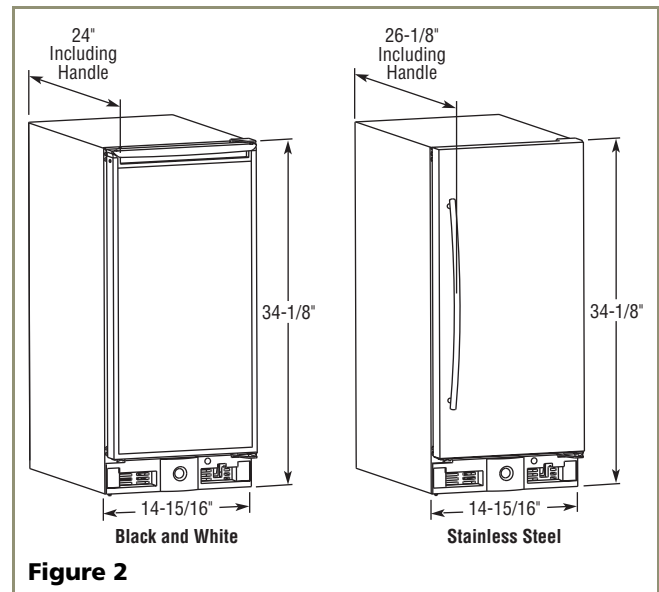

Figure 2

Please note that the unit has adjustable feet that can add one additional inch to height during leveling or to match adjacent cabinets (see **Figure 44** on **Page 17**.)

Door Swing/Clearances Information

Black and White units have a zero clearance for the door to open 90° (see **Figure 3**). Stainless Steel models require a minimum of 2-1/8" door clearance to accommodate the handle if the unit is installed next to a wall or similar type of structure.

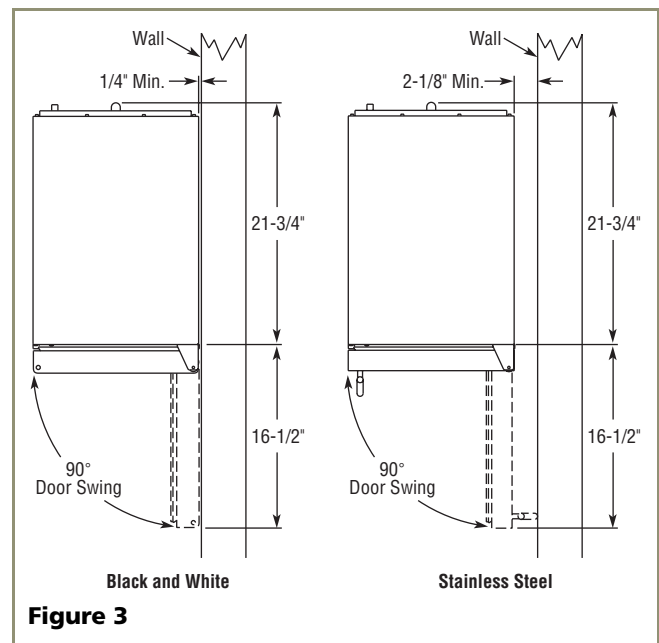

Figure 3

Reversing the Door

(Black and White Units Only)

All U-Line units (except Stainless Steel models) may be left- or right-hand opening. The door opening is easily reversed by moving the hinge hardware to the opposite side. The top hinge hardware will be used on the bottom of the other side and the bottom hinge hardware will be used on the top of the other side (see **Figure 4**).

To reverse the door:

1. Remove top hinge screw pin from door (7/64" Allen wrench or Phillips screwdriver, depending on your unit's construction) (see **Figure 5**). Remove door by tilting forward and lifting off bottom hinge pin.
2. Remove plastic screw plugs (3 each, top and bottom) from new hinge location. Do not discard (see **Figure 6**).

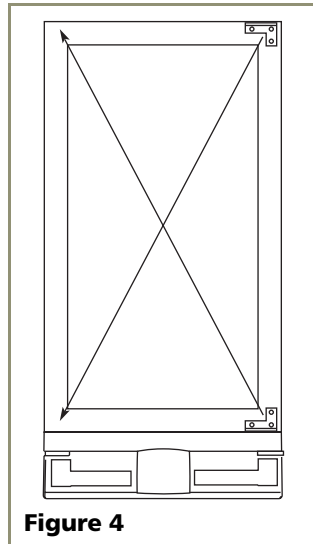

Figure 4

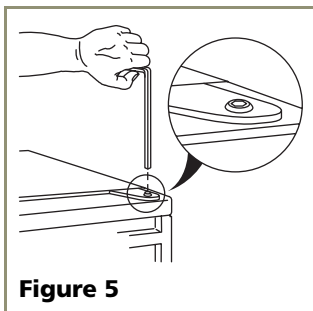

Figure 5

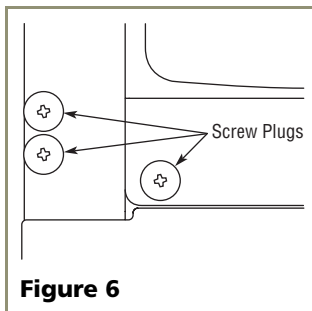

Figure 6

3. Remove top hinge (3 screws), reinstall hinge screw pin, and remount on opposite side **BOTTOM** (see **Figure 7**).

4. Remove the two door closer inserts from the existing bottom hinge and install as shown on the new bottom hinge (see **Figure 8**).

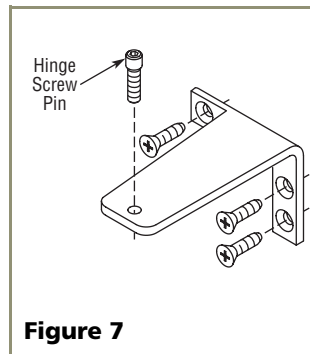

Figure 7

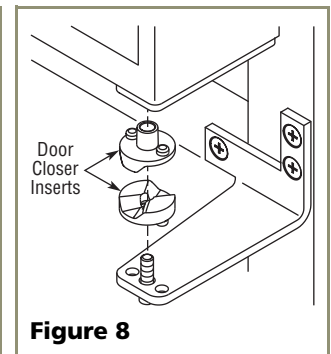

Figure 8

5. Remove existing bottom hinge (3 screws) and remount on opposite side **TOP**. Remove hinge screw pin.
6. Remove the plastic hole plug from the top of the door to allow the pivot pin to be inserted in the new location. Install the plug into the vacated hole on the opposite side.
7. With bottom of door facing up, remove pivot plate (2 screws), flip over, and remount on opposite side of door (see **Figure 9**). Be sure notch in plate faces center.

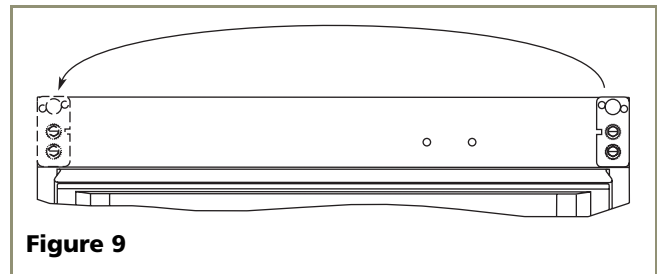

Figure 9

8. Holding door upright with top of door tilted forward, place hole of door pivot plate on bottom hinge screw pin (see **Figure 10**).
9. Tilt top of door into position in top hinge and install top hinge screw pin.
10. Install plastic screw plugs removed in Step 2 in old hinge holes (3 each, top and bottom).

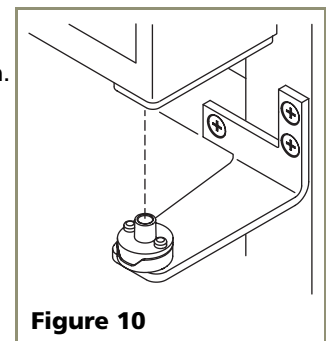

Figure 10

Other Site Requirements

Power Supply

The unit requires a grounded and polarized 115 VAC, 60 Hz, 15A circuit (normal household current). See *Electrical Specifications* on **Page 16**.

Water Supply

The unit requires a 1/4-inch OD water supply line and a shut-off valve. For more information see **Page 15**.

Drain

The unit's generous 7-inch drain connection height extends the distance the unit can be located from a gravity drain. For more information see **Page 12**.

IMPORTANT

Drain can NOT be located directly below unit. Unit has a solid base that will not allow unit to drain below itself.

Environmental Requirements

The surrounding air temperature must be at least 50°F (10°C) but must not exceed 110°F (40°C). High ambient temperature ranges and warmer water supply will cause reduced ice production. Black and White units may be installed outdoors in a covered area. Stainless Steel CLR2060 units are deemed suitable for outdoor use by UL. The unit must not be located near heat-generating equipment or in direct sunlight.

Side-By-Side Installation Instructions

For a complete refreshment center, install your CLR2060 Clear Ice Maker beside a U-line Refrigerator, Combo, or Wine Captain Model (see **Figure 11** for typical cut-out). Note that each Side-By-Side Installation will be different.

- Cut-out width for a side-by-side installation is the total of the widths listed under *Cut-Out Dimensions* in each unit's Installation Guide.

For example:

Placing a CLR2060 Clear Ice Maker next to a 2015R Refrigerator would require a cut-out width of:
 $15\text{-}3/16" + 15\text{-}3/16" = 30\text{-}3/8"$

Placing a CLR2060 Clear Ice Maker next to a 2075R Refrigerator would require a cut-out width of:
 $15\text{-}3/16" + 24\text{-}3/16" = 39\text{-}3/8"$

- No trim kit is required. However, 1/4-inch space needs to be maintained between the units to ensure unobstructed door swing.
- Units must operate from separate, properly grounded electrical receptacles placed according to each unit's *Electrical Specifications*.

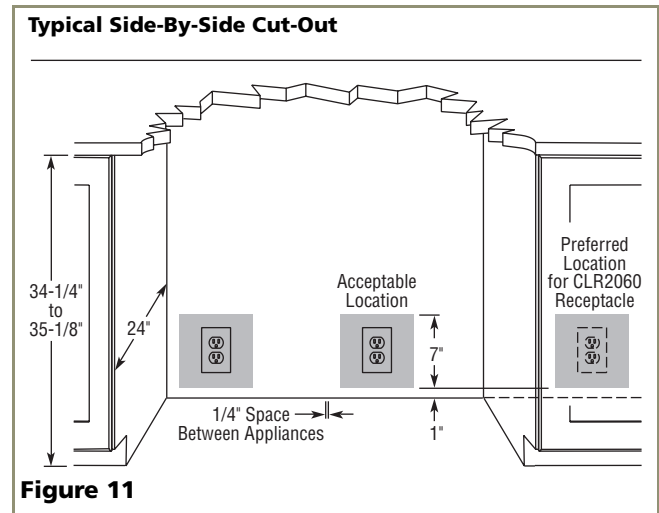

4 Prepare and Install Door Panel

(Black and White Units Only)

Two types of custom door panels can be installed on your Black or White unit to harmonize with or accent the surrounding décor: a Custom 1/4" Insert or a Full Overlay. If no custom door panel is used, go on to **5 Adjust Door**.

Custom 1/4" Door Panel Insert

Door Panel Preparation

A custom door panel can be inserted into the doorframe. Custom door panels can be flat or raised, as long as the maximum panel thickness where inserted into the door reveal (channel) is 1/4"-thick. For raised panels, the depth of the reveal is 1/4" on all four sides.

IMPORTANT

Raised panels will reduce the door's 90° swing/zero clearance if the unit is installed next to a wall or similar type of structure (see **Page 4**).

Cut the panel insert to the following dimensions.

Custom 1/4" Dimensions:

Width: 14-1/32"

Height: 28-5/32"

The door panel must not weigh more than 20 lbs.

Door Panel Installation

Install the insert as follows:

CAUTION

Use care when handling the insert. Insert edges may be sharp.

1. Remove top hinge screw pin (7/64" Allen wrench or Phillips screwdriver, depending on your unit's construction, see **Figure 12**). Remove door by tilting forward and lifting off bottom hinge pin.

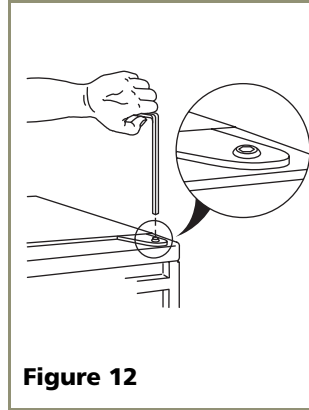

Figure 12

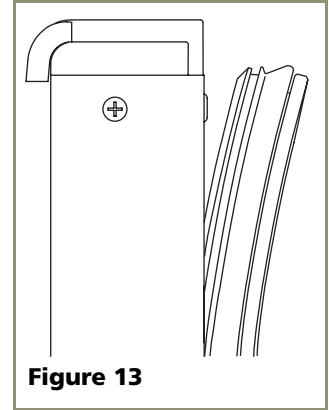

Figure 13

2. Pull door gasket out of groove (top edge of door only). Start in the middle and pull outward, moving toward the edge (see **Figure 13**). This may take some force. Do not remove the three screws behind gasket.
3. Remove two outside screws holding door handle. Slightly separate door handle from door (see **Figure 14**).
4. Pull handle up and off.
5. Remove and discard existing panel.
6. Slide custom door panel insert into 1/4-inch channel in door front.
7. Holding door gasket out of the way, replace handle on door, making sure it is seated properly on insert and that screw holes line up.
8. Install two small screws removed in Step 3.
9. Starting at the corners and working inward, push door gasket into place on door.
10. Place door on bottom hinge pin and install upper hinge screw. Go on to **5 Adjust Door**.

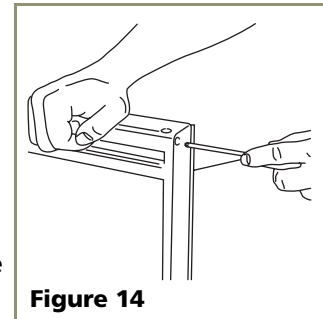

Figure 14

Full Overlay Door Panel

Door Panel Preparation

A full overlay door panel completely covers the doorframe and handle to give a built-in appearance. See your U-Line dealer for the optional Full Overlay Door Panel Kit (P/N U-OL2015B — Black or P/N U-OL2015W — White). Appropriate hardware, Modified Handle, Replacement Hinges and a copy of these instructions will be included in the kit.

1. Cut the overlay to the following dimensions (see **Figure 15**).

Full Overlay Dimensions:

Width: 14-3/4"

Height: 29-7/8"

The door panel must not weigh more than 20 lbs.

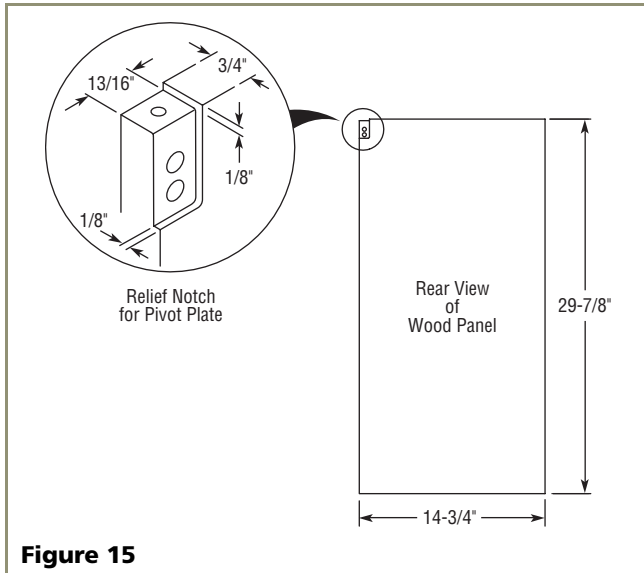

Figure 15

IMPORTANT

Rear View of wood panel for right-hand hinge shown. Use mirror image for left-hand hinges.

2. Create a relief (**Figure 15**) for pivot plate by cutting notch in top corner and coinciding back corner of overlay panel. Refer to **Figure 16** for exact specifications.

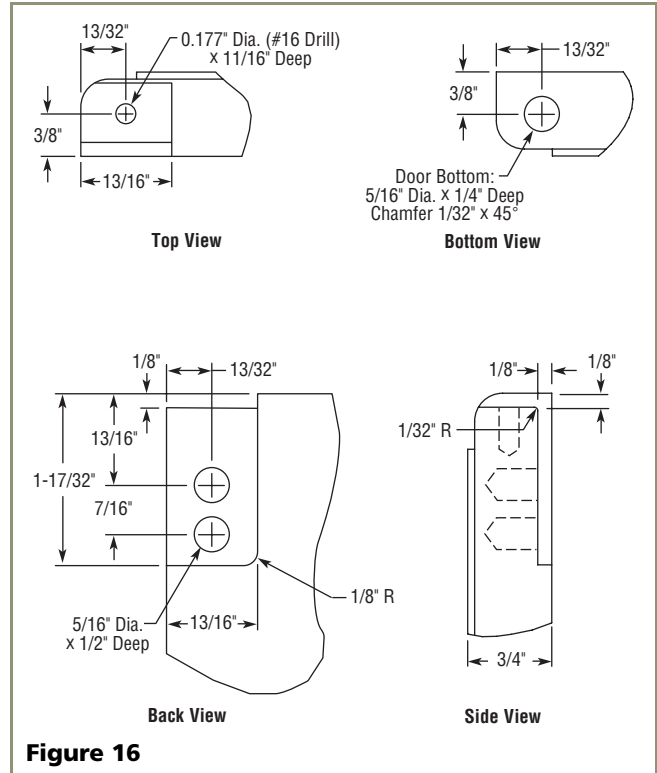

Figure 16

Route notch in top corner of overlay panel as shown (see Top and Side Views). Top of notch is entire depth of panel, front to back.

Width: 13/16"

Depth: 1/8"

Route notch in backside of top corner of overlay panel (see Back and Side Views).

Width: 13/16"

Depth: 1/8"

Height: 1-17/32" from top edge of panel (less 1/8" for depth of notch on top of panel)

Radius of corner notch: 1/8" (see Back View)

3. Drill holes for pivot plate mounts (see **Figure 16**, Back View).

5/16" diameter x 1/2" deep, from the routed surface

CAUTION

Be careful not to drill too deep! Drilling holes too deep may destroy your door panel.

4. Drill hole for upper door hinge (top of panel) (see **Figure 16**, Top View).
0.177" diameter
(#16 drill) x 11/16" deep
5. Drill hole for lower door hinge (see **Figure 16**, Bottom View).
5/16" diameter x 1/4" deep

⚠ CAUTION

It is important to ensure that all drilled holes are drilled to the correct depth in order to avoid splits in the wood when hardware is installed.

Installation Instructions

Removing Existing Door

1. Remove top hinge screw pin (7/64" hex key or Phillips screwdriver, depending on your unit's construction). Remove the door by tilting forward and lifting off the bottom hinge pin.
2. Pull door gasket out of the groove (top edge of door only). Start in the middle and pull outward, moving toward the edge (see **Figure 17**). This may take some force.

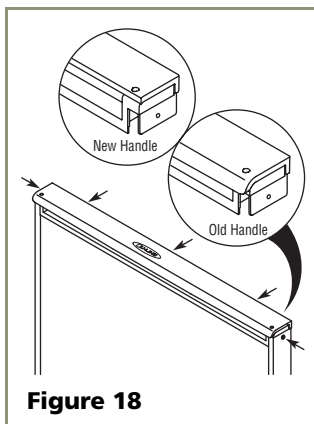
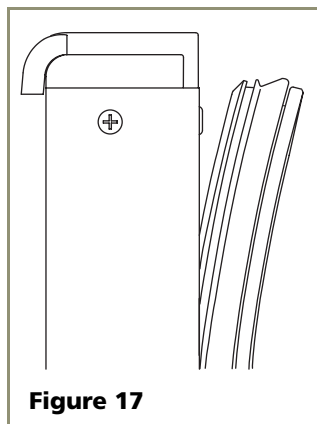

3. Remove the three screws located on the back of the handle (see **Figure 18**).

4. Remove the top handle and discard. (This handle will be replaced with the Modified Handle included in the Full Overlay Door Panel Kit.)
5. Remove the two screws located on both sides of the lower handle. Remove the handle.
6. Attach the Modified Handle to the lower handle using the three screws removed in Step 3. Set aside.
7. Slide the existing door panel out of the doorframe.

Attaching the Full Overlay Panel

1. Tap nylon inserts into the top holes drilled in the overlay panel. Use two #6 screws to attach top pivot bracket to the overlay panel (see **Figure 19**).

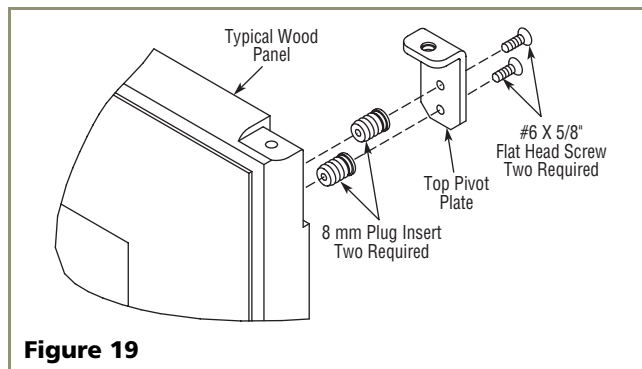

2. If a user-supplied cabinet handle will be used, attach its hardware to the overlay panel at this time.
3. Place and tape the existing door panel on the back of the overlay panel (see **Figure 20**) and drill holes through both panels according to **Figure 21**. Remove tape adjoining the panels and enlarge the six holes in the overlay panel using a 0.201" (#7) drill.

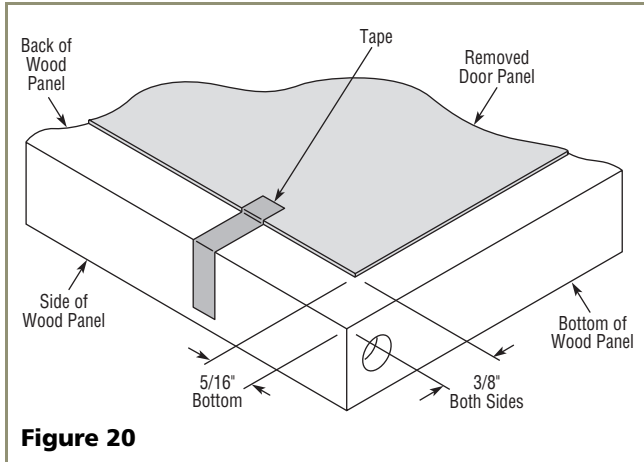

Figure 20

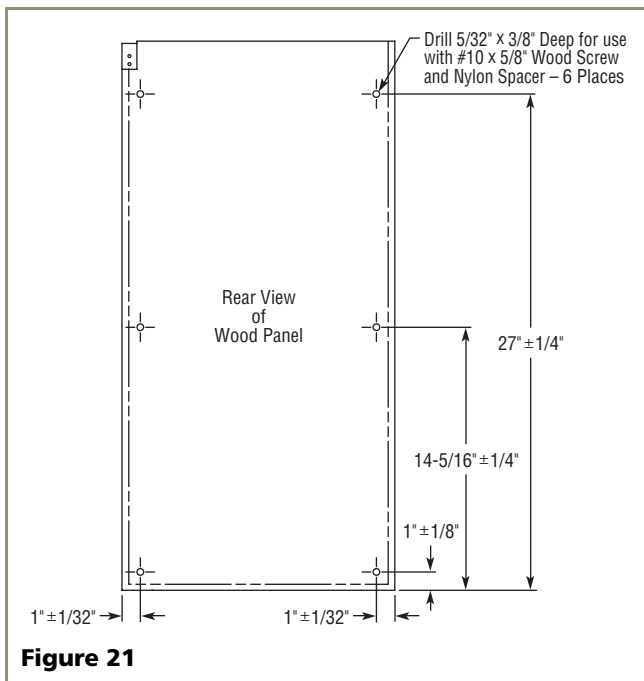

Figure 21

4. Attach the door panel to the overlay panel using #10 x 5/8" wood screws and nylon spacers. The nylon spacers fit between the overlay panel and the door panel as shown in **Figure 22**. The spacers allow the original door panel to slide back into the 1/4"-thick door reveal (channel).

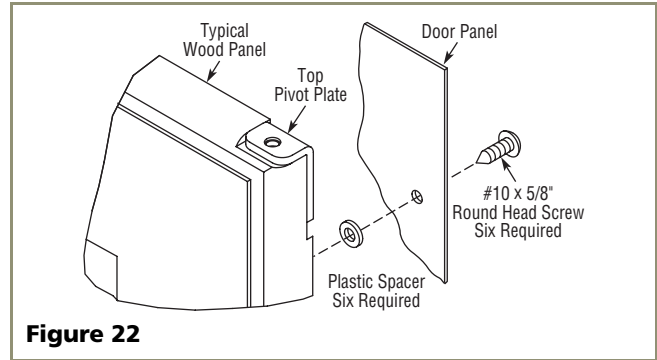

Figure 22

5. Remove the existing bottom pivot plate and replace with the Full Overlay pivot plate (see **Figure 23**).

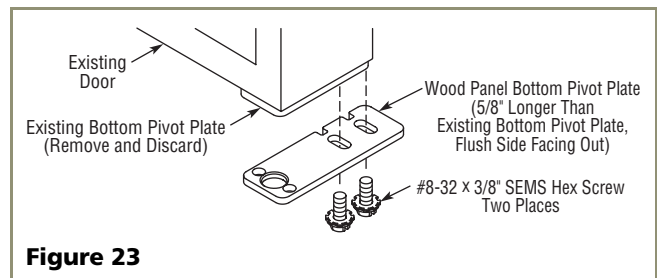

Figure 23

IMPORTANT

Door panel and overlay panel must be aligned properly or the door will not operate correctly.

Assembling the Door

1. Install the assembled panel by sliding the original door panel back into the doorframe.
2. Replace the two-piece Modified Handle assembly and secure with the two screws removed in Step 5 under *Removing Existing Door*.
3. Starting at the corners and working toward the center, push the door gasket back into place.

Installing the Door

1. Remove the existing hinges from the unit, saving the door closure assembly.
2. Install the new Replacement Top Hinge onto the unit (see **Figure 24**).

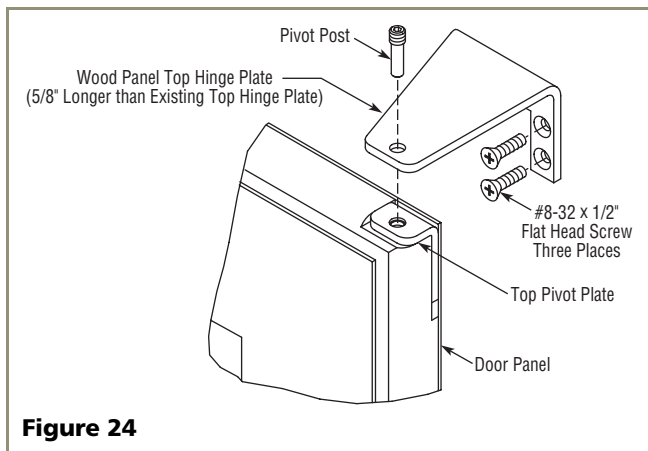

Figure 24

3. Install the pivot post into the new Replacement Bottom Hinge (using the 7/64" hex key or Phillips screwdriver) and install the hinge onto the unit.
4. Replace the door closure assembly onto the bottom pivot post (see **Figure 25**). Be sure that bosses on closers align with holes in hinge and hinge plate.

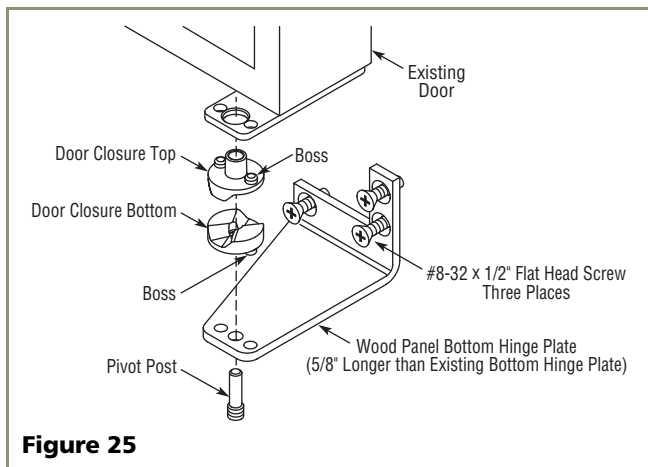

Figure 25

IMPORTANT

Pivot posts must be cleaned. Closers must also be clean and greased to ensure proper operation.

5. Place the modified door onto the pivot post.
6. Position door and install the pivot post into the top hinge (using the 7/64" hex key or Phillips screwdriver).
7. Adjust door as needed for proper closure. Go on to **5 Adjust Door**.

5 Adjust Door

Checking Door Alignment

The unit's door is aligned at the factory before shipment. However, its alignment could have been disturbed during shipment or during door panel installation.

IMPORTANT

Properly aligned, the door should be 1/8" below the top of the unit's cabinet, NOT flush with the top (see **Figure 26**).

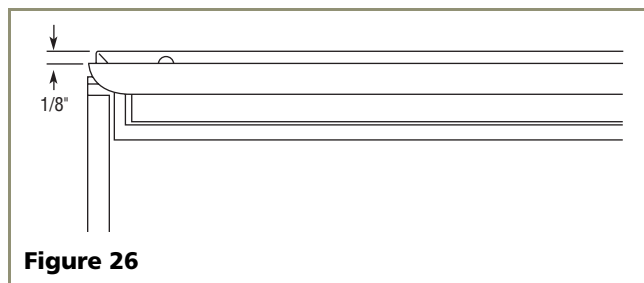

Figure 26

1. Compare the top edge of the door to the top edge of the cabinet.
2. If the door edge is 1/8" below and parallel to the top of the cabinet, go on to **6 Prepare Plumbing**. If it is not, note whether the side opposite the hinge needs to be moved UP or DOWN, and use the following procedure.

Adjusting Door Alignment

1. Remove top hinge screw pin (7/64" Allen wrench or Phillips screwdriver, depending on your unit's construction, see **Figure 27**). Remove door by tilting forward and lifting off bottom hinge pin.
2. With door upside-down, loosen but do not remove the two screws on the door's bottom hinge plate.

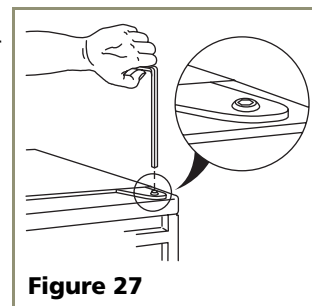

Figure 27

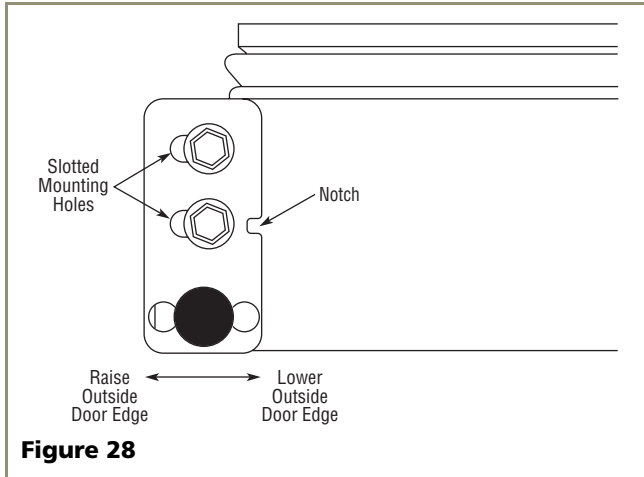

Figure 28

3. See **Figure 28**. If the top far edge of the door needs to move UP, move the hinge plate toward the outside of the door and retighten screws. If the top far edge of the door needs to move DOWN, move the hinge plate toward the inside of the door and retighten screws.
4. Mount the door to recheck alignment and repeat steps 2 and 3 if further adjustment is necessary.
5. When top edge of door is parallel to top edge of cabinet, remove the door and ensure the two screws are secure.
6. Remove the door closers from the bottom hinge, clean thoroughly and lubricate the mating surfaces with petroleum jelly.
7. Reinstall the closers, lining up the bosses with holes in hinge and hinge plate (see **Figure 29**).
8. Mount the door, install top hinge pivot pin and go on to **6 Prepare Plumbing**.

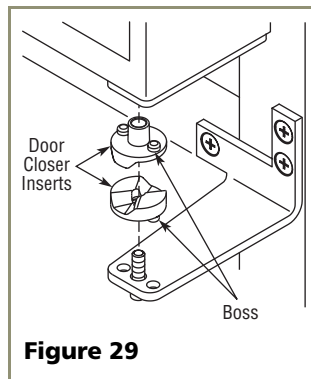

Figure 29

6 Prepare Plumbing

⚠ CAUTION

Plumbing installation must observe all state and local codes. All water and drain connections **MUST BE** made by a licensed/qualified plumbing contractor. Failure to follow recommendations and instructions may result in damage and/or harm.

Drain Connection

IMPORTANT

Drain can **NOT** be located directly below unit. Unit has a solid base that will not allow unit to drain below itself.

The CLR2060 can be installed using a Gravity Drain, a Factory-Installed Drain Pump (U-Line P60) or a Locally-Installed Drain Pump. Drain lines must have a 5/8-inch inside diameter. The floor drain must be large enough to accommodate drainage from all attached drains.

Follow these guidelines when installing drain lines to prevent water from flowing back into the ice maker storage bin and/or potentially flowing onto the floor, causing water damage:

Gravity Drain

A Gravity Drain may be used if:

- Drain line has at least a 1-inch drop per 48 inches of run (1/4 inch per foot).
- Drain line does not create traps or created traps are vented (see **Figure 30**).

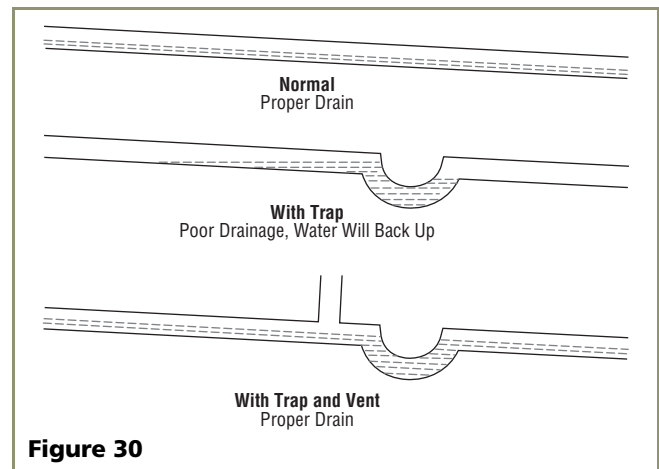
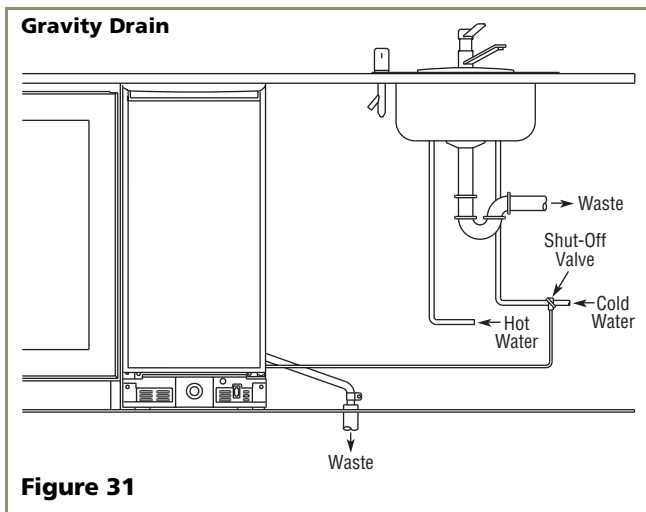

Figure 30

See **Figure 31** for a typical Gravity Drain installation.



If using a Gravity Drain:

1. Attach the 5/8-inch ID drain connection on the back of the unit to a 5/8-inch OD rigid tube, using a worm clamp.
2. Attach the other end of the rigid tube to your 5/8-inch ID drain line with a worm clamp.
3. Insulate the drain line, if necessary to prevent condensation. Go on to *Water Supply Connection*.

Factory-Installed Drain Pump

If your drain line will run up to a stand pipe, disposal assembly or spigot assembly or does not otherwise meet the requirements for a Gravity Drain, you may have ordered the CLR2060 with a U-Line P60 Drain Pump. See **Figures 32, 33 and 34** for typical installations requiring a Drain Pump. If you need to install a P60 Drain Pump into your unit, see *Locally-Installed Drain Pump* on **Page 14**.

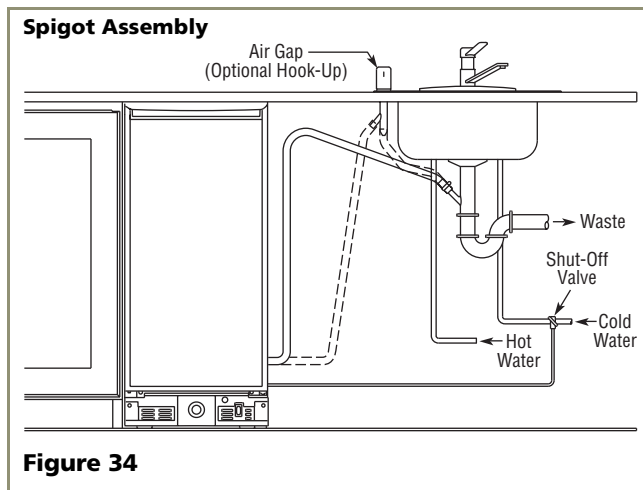
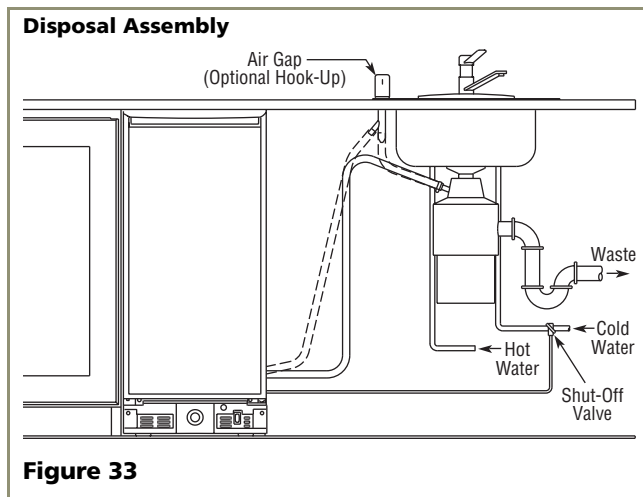
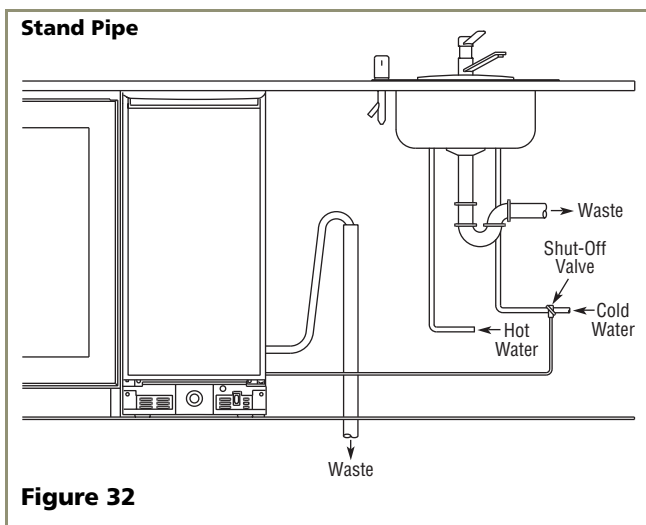

IMPORTANT

Before installing your U-Line CLR2060 with Factory-Installed U-Line P60 Pump, it is extremely important to check and test all hose connections at the drain pump. There is a possibility that hose connections may have loosened during shipment.

⚠ WARNING

To prevent accidental electrocution, make certain that the floor surfaces surrounding the unit are dry whenever power is removed from, or applied to, the unit.

To check and test hose connections:

1. Make certain the unit is not plugged into an electrical outlet.
2. Carefully push the power cord grommet through the hole in the back panel (see **Figure 35**).

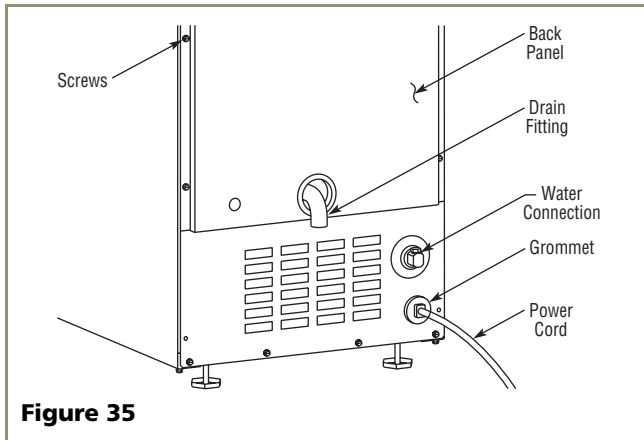

Figure 35

3. Remove 12 screws and back panel.

⚠ WARNING

Back panel serves as a guard. DO NOT put your hands inside the ice maker cabinet or attempt to touch any components except the discharge tube during testing. Failure to follow this warning could result in serious personal injury or death.

4. Check that the clamps and hose connections are tight at the following areas (see **Figure 36**):
 - Discharge tube (A)
 - Drain tube (B)
 - Vent tube (C)

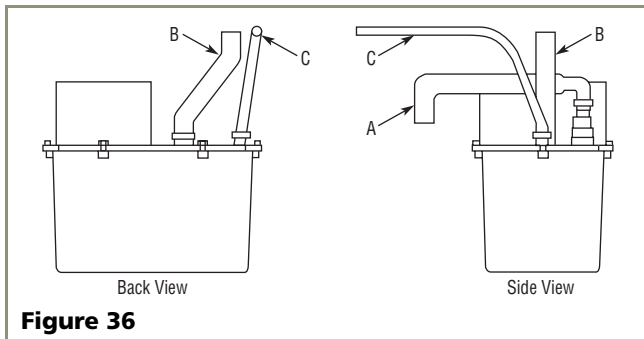

Figure 36

5. Place a suitable container beneath the pump's discharge tube. (The bucket must be able to hold a minimum of one gallon.)
6. Plug the ice maker power cord into a properly grounded, polarized electrical outlet.
7. Verify pump operation by pouring one gallon of water into the ice storage bin of the ice maker. The pump should energize and pump the water into the container.
8. At this time, verify that all tube and clamp connections are tight and leak free.
9. Unplug unit power cord from electrical outlet.
10. Reinstall back panel.

To connect to drain:

1. Attach the 5/8-inch ID drain connection on the back of the unit to a 5/8-inch OD rigid tube, using a worm clamp.
2. Attach the other end of the rigid tube to your 5/8-inch ID drain line with a worm clamp.
3. Insulate the drain line, if necessary to prevent condensation. Go on to *Water Supply Connection*.

Locally-Installed Drain Pump

If a gravity drain connection is not possible, and you have not purchased the CLR2060 with factory-installed pump, we strongly recommend the use of the U-Line P60 drain pump. The U-Line P60 drain pump is available through your Dealer, or direct from U-Line with complete installation instructions. If a pump other than the U-Line P60 drain pump is to be used, it must meet the following specifications:

- It must be UL listed and have a UL listed, 120 VAC, 3-wire grounded power cord.
- It must have overall maximum outside dimensions of 8-3/4" wide x 5-3/4" deep x 7-3/4" high.
- It must have a minimum flow rate of 15 gallons per hour at 10 feet of lift.
- It must have a sealed sump which does not allow water leakage in the case of a power outage, restricted drain or pump failure.
- It must have a check valve in the discharge line to prevent waste water return to the pump.
- It must have an overflow protection control which will shut off power to the ice maker in the event of a pump failure.
- It must have an operating temperature range of 50°F to 110°F (10°C to 40°C).

⚠ CAUTION

In the event of a power outage, restricted drain or pump failure, the failure to use the U-Line P60 drain pump or a pump with the above listed specifications, could result in substantial water leakage and pooling with severe and costly water damage and related consequential damages and harm.

Water Supply Connection

When connecting the water supply, follow these guidelines:

- Review the local plumbing codes before you install the unit.
- Connect to the cold water supply.
- The water pressure should be between 20 and 120 psi.
- Install a shut-off valve in the 1/4 inch OD water supply line.
- Connect sufficient tubing to the unit so that tubing may be looped, allowing the unit to be removed for cleaning and servicing (see **Figure 40**). However, make certain that the tubing is not pinched or damaged during installation.
- U-Line recommends the use of copper tubing for installation.

To connect to water supply:

1. Install the 1/4 inch OD copper water line from the main water source (see **Figure 37**).

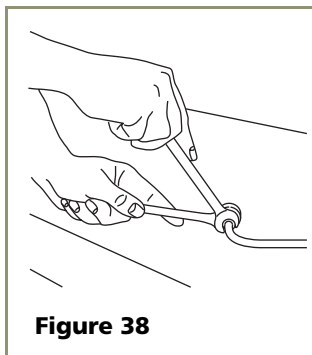
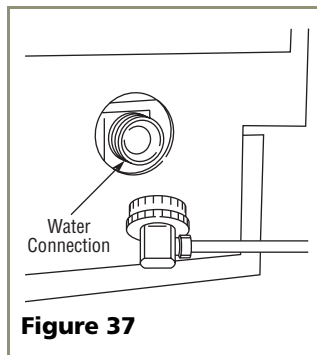

2. Locate the compression fitting and ferrule packed with this guide. Slide the compression fitting and ferrule over the 1/4-inch OD water supply line. Do not use thread sealing compound or tape. Using two wrenches, tighten the compression fitting on the supply line (see **Figure 38**).

3. Carefully bend the water supply line into position and connect the line to the solenoid valve (see **Figure 39**). Avoid kinking the water supply line.

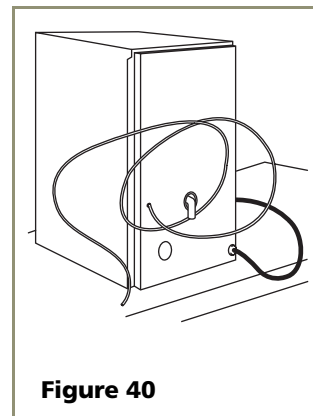
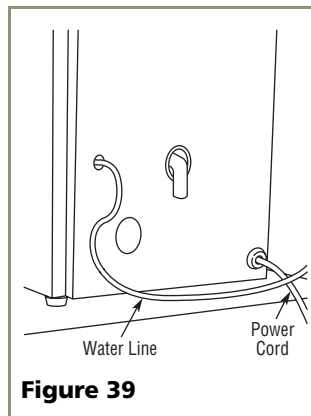

IMPORTANT

Normal operation creates some vibration. A water supply line contacting cabinet wall may cause excessive noise during operation or damage to the line.

4. For recessed installations, allow extra water supply line length to provide slack for easy removal from the recessed area (see **Figure 40**). This will also safeguard against kinking the line.
5. Go on to **7 Prepare Power Supply**

7 Prepare Power Supply

Electrical Specifications

⚠ CAUTION

Electrical installation must observe all state and local codes. This unit requires connection to a grounded (three-prong), polarized receptacle that has been placed by a qualified electrician.

The unit requires a grounded and polarized 115 VAC, 60 Hz, 15A power supply (normal household current). An individual, properly grounded branch circuit or circuit breaker is recommended. GFCI (ground fault circuit interrupter) is usually not required for fixed location appliances and is not recommended for your unit because a GFCI could be prone to nuisance tripping. However, be sure to consult your local codes.

See **Figure 41** for recommended receptacle location. Plugging the unit into a receptacle located behind an adjacent cabinet will allow the CLR2060 to be more easily serviced with self-diagnostics without disturbing your installation.

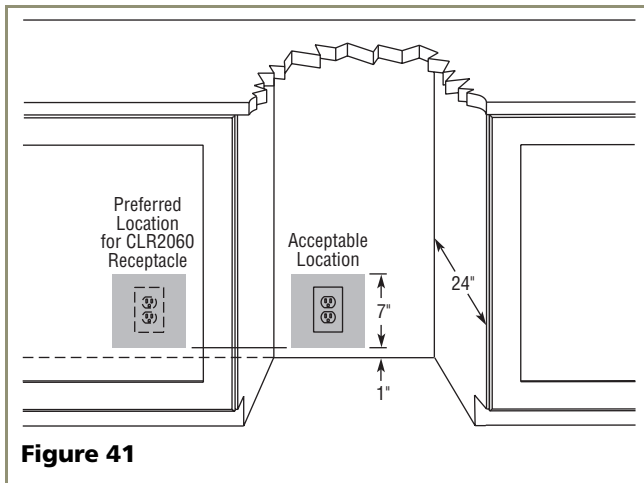

Figure 41

⚠ WARNING

SHOCK HAZARD — Electrical Grounding Required.

- Never remove the round grounding prong from the plug and never use a two-prong grounding adapter.
- Never use an extension cord to connect power to the unit.

Go on to **8 Level the Unit**.

8 Level the Unit

Leveling Information

IMPORTANT

It is extremely important that the unit is level. If it is not level, the ice mold will not fill evenly.

A unit that is not level can cause a reduction in ice rate, uneven sized cubes or water spilling into the storage area, which will cause the ice in the bin to melt prematurely (see **Figure 42**).

Remember that floors near drains have a tendency to slope towards the drain.

1. Use a level to check the levelness of the ice maker from front to back and from side to side. Level should be placed along top edge and side edge as shown (see **Figure 43**).

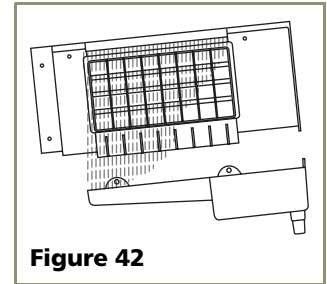

Figure 42

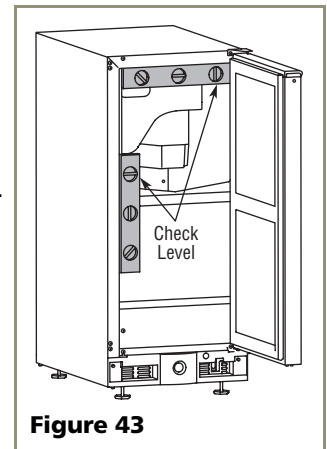

Figure 43

2. If the ice maker is not level, adjust the feet on the corners of the unit as necessary (see **Figure 44**).

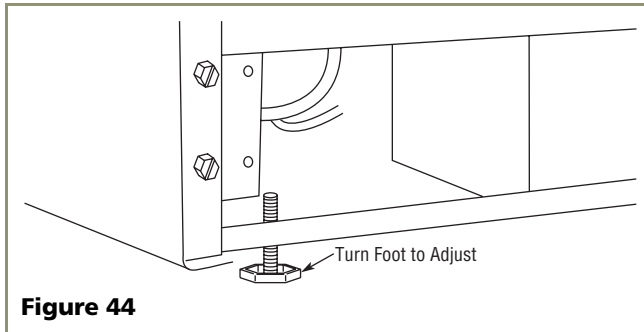

Figure 44

3. Check the levelness after each adjustment and repeat the previous steps until the unit is level. Go on to **9 Install the Unit**.

Installation Tip

If the room floor is higher than the floor in the cut-out opening, adjust the rear feet to achieve a total unit rear height of 1/8" less than the opening's rear height. Shorten the unit height in the front by adjusting the front feet. This allows the unit to be gently tipped into the opening. Readjust the front feet to level the unit after it is correctly positioned in the opening.

9 Install the Unit

Installation of the CLR2060

1. Open the water supply valve in the main water source.
2. Plug in the power cord.
3. Gently push the unit into position. Be careful not to kink the drain or water supply line or entangle the electrical cord.
4. Re-check the leveling, from front to back and side to side. Make any necessary adjustments. The unit's top surface should be approximately 1/8" below the countertop.
5. Test the drain system by pouring one gallon of water into the ice bin. The water should drain freely and there should be no leakage.

Installation Troubleshooting

Q: Problem

Water is leaking under the unit.

A: Solution

A water leak under the unit is most likely caused by a bad connection in the water supply line. Make sure the water line's brass fitting is screwed tight to its valve and threaded correctly. Make sure the fill tube's connection to the water line is also tight. Check drain line to make sure it has not been disconnected from drain connection on back of the unit or disconnected from the drain.

Q: Problem

The door remains open unless it is pushed closed.

A: Solution

The hinges should be self-closing when the door is open approximately 8". If this is not the case, make sure the closers (at the bottom of the hinge pin) are clean, greased and installed correctly. Also, re-check leveling from front to back of the unit and readjust if necessary. Make sure that pivot plate is installed correctly.

Q: Problem

The custom overlay door was designed to align with the rest of the cabinet doors, but the unit has crept forward.

A: Solution

First, make sure that the electrical cord and water supply line are not obstructing the installation. If they are not, there is mostly likely not enough room allowed for the drain connection on the rear of the unit. You may need to alter the wall behind the unit to accommodate the drain connection.

10 Start-Up for the First Time

Initial Start-Up

Once installation and leveling is complete, the unit is ready for initial start-up and operation. The cycle selector switch is located in the front grille (see **Figure 45**).

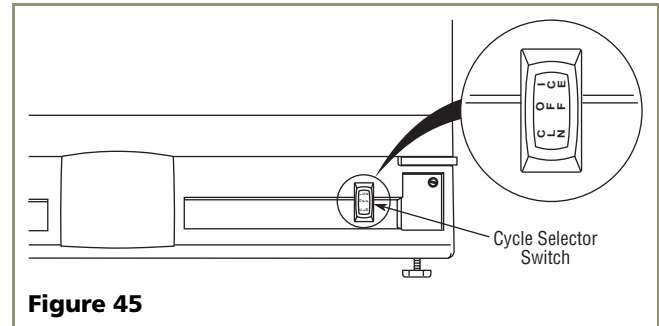

Figure 45

1. Open the door and remove the cover in front of the evaporator by gently compressing and pulling forward. This will enable you to observe the water flow over the evaporator.
2. Check that the overflow tube is inserted securely into the water trough.
3. Put the cycle selector switch (in the grille) in the ICE position (press the switch up). The water fill valve will energize and fill the water reservoir. The water fill valve shuts off after approximately 180 seconds (3 minutes). The compressor begins to operate.

4. Watch the water flow over the evaporator assembly (ice cube tray) to familiarize yourself with the operation. Upon initial start-up, water flow over the evaporator may be uneven. This may cause uneven sized cubes or water spilling into the ice storage bin. This is a normal situation and will correct itself within the first 24 hours of operation.
5. Replace the evaporator cover.

IMPORTANT

It is possible that dirt or scale will dislodge in the water line. Always throw away all ice cubes made during the first two to three hours of operation.

About Settings

All settings are factory preset. No adjustments should be necessary at this time. For information about Ice Cube Thickness, see the User Manual.

Start-Up Troubleshooting**Q: Problem**

Unit does not appear to turn on when switch is set to ICE.

A: Solution

Remember that the compressor will not operate until the water has been filling for about 3 minutes. Make sure unit is plugged in and outlet has power (circuit breaker has not tripped). If the unit is equipped with a drain pump, check that the drain line is not obstructed — unit will shut down due to the safety design of the pump if water cannot drain.

Q: Problem

Water does not appear to be flowing into unit.

A: Solution

Check that the water is connected and turned on, the line is not obstructed and the overflow tube is inserted securely into water trough.

Q: Problem

The unit has been operating for 24 hours and water is still not flowing evenly over evaporator or ice seems slow to release.

A: Solution

Level unit for even water flow. Uneven water flow will reduce ice rate and cause water to spill in ice bin.

IMPORTANT

See the User Manual's *Troubleshooting Guide* for more solutions.

Échelon™ Series

Who to Call

Service Information

If the need for service arises, contact the dealer from whom the unit was purchased. State the Model Number and Serial Number and explain the problem. The Model and Serial Number plate is located inside unit at upper right hand corner.

If you need to locate a service company, you can go online at **www.U-LineService.com** and search for a service company by zip code.

For more than four decades, U-Line has distinguished itself as the leader in built-in undercounter ice making, refrigeration and wine storage appliances.

Échelon™ SERIES / *O r i g i n s* SERIES

U-Line Corporation, located in Milwaukee, WI, is a family operated manufacturer of built-in undercounter icemakers, Combo® icemaker/refrigerators, Wine Captain® wine storage units, refrigerators, refrigerated drawers and refrigerator/freezers.