



Échelon™ Series

**Custom 1/4" Drawer Panel
Preparation and Installation
Instructions for
Models C02175DWR and 2175DWRR**

www.U-LineService.com

**Phone (414) 354-0300 • FAX (414) 354-7905
Service & Parts Tech Lines Phone (800) 779-2547 • FAX (414) 354-5696
OnlineService@U-Line.com**

©2006 U-Line Corporation
04/2006

Custom 1/4" Drawer Panel Inserts

Drawer Panel Preparation

Custom drawer panels can be inserted into the drawer fronts. When installing custom 1/4" drawer panels, replacement handles **MUST** be used (part number 26070-01). Custom drawer panels can be flat or raised, as long as the maximum panel thickness where inserted into the drawer front reveal (channel) is 1/4"-thick. For raised panels, the depth of the reveal is 1/4" on all four sides.

IMPORTANT

Raised panels will reduce the drawer's front clearance if the unit is installed facing an appliance or structure.

Cut the panel inserts to the following dimensions.

Custom 1/4" Dimensions:

Width: 23-1/32"

Height: 12-15/32"

The door panels must not have a total weight of more than 20 lbs.

Drawer Panel Installation

Install the insert as follows:

CAUTION

Use care when handling the insert. Insert edges may be sharp.

1. Open drawer. Pull drawer gasket out of groove (top edge of drawer only). Start in the middle and pull outward, moving toward the edge (see **Figure 1**). This may take some force.
2. Remove and save the two outside screws (see **Figure 2**).
3. Remove the original handle and discard.
4. Remove and discard existing panel and cardboard spacer.
5. Slide custom drawer panel insert into 1/4-inch channel in drawer front.
6. Holding drawer gasket out of the way, replace handle on drawer, making sure it is seated properly on insert and that screw holes line up.
7. Install two small screws removed in Step 2.
8. Starting at the corners and working inward, push drawer gasket into place on drawer.

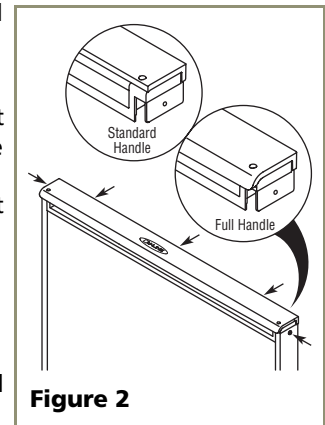
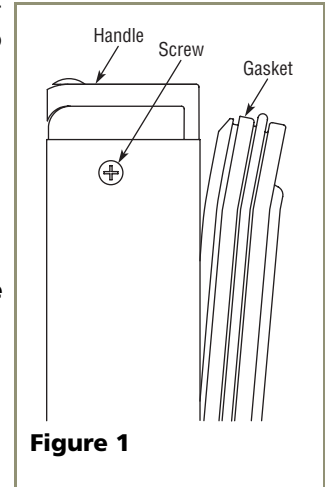

Checking Drawer Alignment

The unit's drawers are aligned at the factory before shipment. However, their alignment could have been disturbed during shipment or during overlay panel installation.

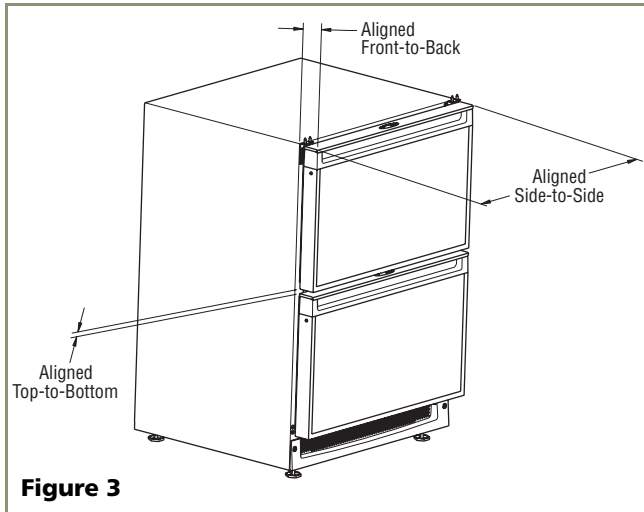

Figure 3

See **Figure 3**. Check each drawer to confirm that it is aligned:

- **Side-to-Side** — When viewed from the top, the drawer front should be square with the sides of the cabinet.
- **Front-to-Back** — When viewed from the side, the drawer front should be straight with the cabinet's sides, not cocked forward or back.
- **Top-to-Bottom** — When viewed from the front, the drawer should be level horizontally.

If either drawer is not aligned, carefully follow instructions to remove that drawer, make the necessary adjustment and re-install the drawer.

Adjusting Drawer Alignment

⚠ WARNING

SHOCK HAZARD — The unit must be unplugged from the wall outlet during drawer removal, adjustment and re-installation.

Drawer Removal

1. Confirm that the unit is unplugged from wall outlet.
2. Unplug the drawer's connection wiring (top drawer only).
3. Remove the mounting screws. See **Figure 4**.
4. Pull the drawer completely out of the unit.

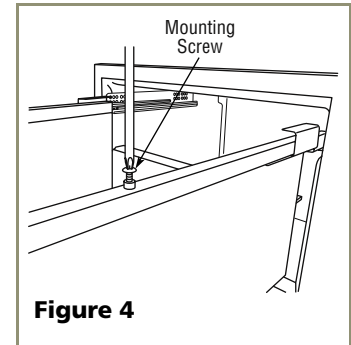

Figure 4

⚠ CAUTION

Use care when handling the drawer. Drawer edges, drawer rail and the unit's slide may be sharp.

IMPORTANT

Drawer adjustments are made by moving the slide that carries the drawer's rail. Minor adjustments may be made by loosening one of the slide's mounting screws, adjusting the slide and retightening the screw. Severe adjustments may be made by removing the slides' mounting screws, drilling new mounting holes and remounting the slide.

Side-to-Side Adjustment

See **Figure 5**. The drawer will need a Side-to-Side Adjustment if, when viewed from the top, the drawer front is not square with the sides of the cabinet. This is caused by one of the slides being mounted too far forward on the unit's liner.

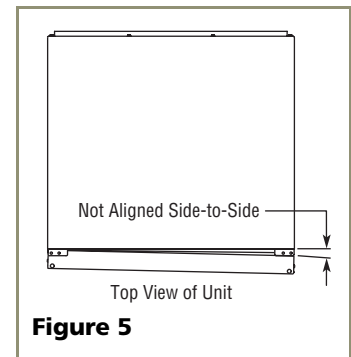
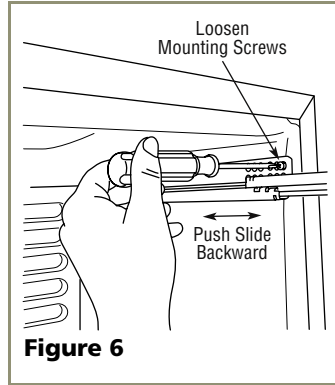

Figure 5

Minor Adjustment:

Note: The mounting holes on the slide are slightly larger than the screws' diameter.

1. Loosen the slide's mounting screws.
2. Push the slide backward.
3. Retighten the screws. See **Figure 6**.



Severe Adjustment:

Note: The slides have extra mounting holes that may be used.

1. Remove the slide's mounting screws.
2. Reposition the slide so it is the same distance from the front of the liner as the other slide. Measure to confirm.
3. Mark new drilling holes using different sets of mounting holes on the slide. See **Figure 7**.

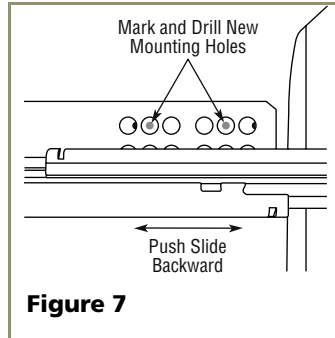

Note: Front location holes are shown. Corresponding rear holes will also need to be marked.

4. Drill all the new holes with a #30 drill bit.
5. Remount the slide.

Front-to-Back Adjustment

See **Figure 8**. The drawer will need a Front-to-Back Adjustment if, when viewed from the side, the drawer front is cocked forward or back. This is caused by the front slide mountings not being level with the rear slide mountings.

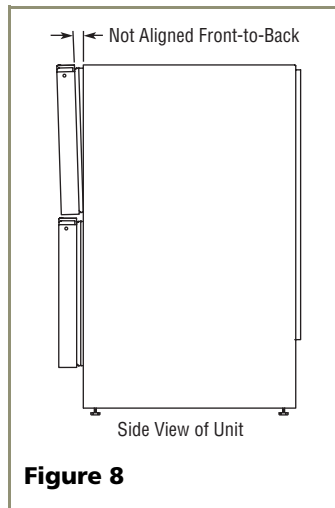

Minor Adjustment:

Note: The mounting holes on the slide are slightly larger than the screws' diameter.

1. Loosen one slide's mounting screws.
2. Level the slide.
3. Retighten the screws. See **Figure 9**.
4. Repeat procedure for the other slide.

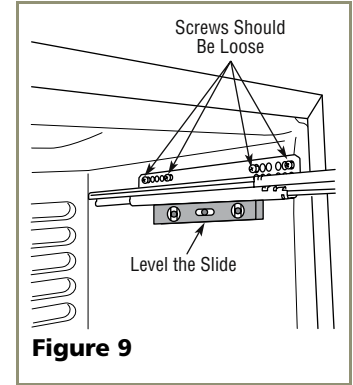

Severe Adjustment:

Note: The slides have extra mounting holes that may be used.

1. Loosen one slide's rear mounting screws.
2. Remove the slide's front mounting screws.
3. Reposition the slide so it is level.
4. Mark new front drilling holes using a different set of mounting holes on the slide. See **Figure 10**.
5. Drill the new holes with a #30 drill bit.
6. Remount the slide.
7. Repeat procedure for the other slide.

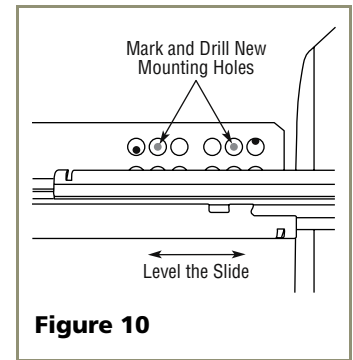

Top-to-Bottom (and Left-to-Right) Adjustment

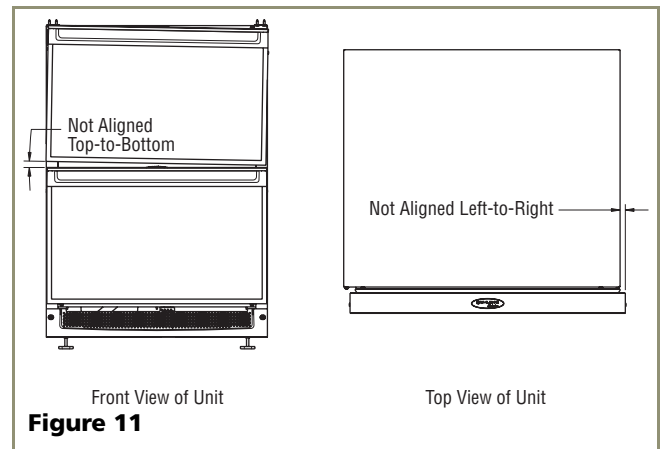

See **Figure 11**. The drawer will need a Top-to-Bottom Adjustment if, when viewed from the front, the drawer is not level horizontally. Viewed from the top, one side will protrude. This is caused by one of the slides being mounted higher than the other slide on the unit's liner.

Échelon™ Series

Minor Adjustment:

Note: The mounting holes on the slide are slightly larger than the screws' diameter.

1. Loosen one slide's mounting screws.
2. Push the slide upward or downward to match the position of the other slide.
3. Retighten the screws. See **Figure 12**.

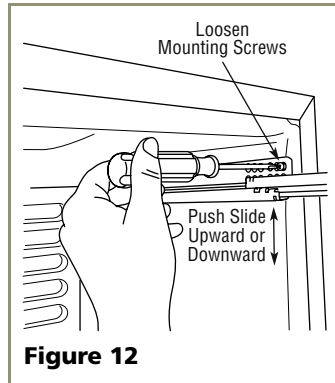

4. Repeat the procedure with the other slide if necessary.

Severe Adjustment:

Note: The slides have extra mounting holes that may be used.

1. Remove one slide's mounting screws.
2. Reposition the slide so it is the same distance from the bottom of the liner as the other slide. Measure to confirm.
3. Mark new drilling holes using different sets of mounting holes on the slide. See **Figure 13**.

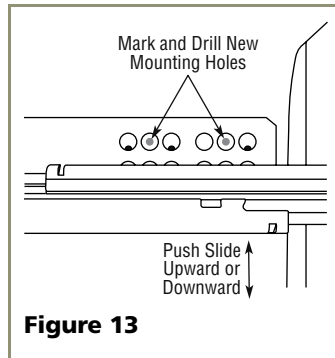

Note: Front location holes are shown. Corresponding rear holes will also need to be marked.

4. Drill all the new holes with a #30 drill bit.
5. Remount the slide.

Re-installation of Drawer

CAUTION

Use care when handling the drawer. Drawer edges, drawer rail and the unit's slide may be sharp.

1. Set the drawer's rails onto the slides.
2. Re-install the rails' mounting screws. See **Figure 4** on **Page 3**.
3. Plug in the drawer's connection wiring (top drawer only).

Who to Call

Service Information

If the need for service arises, contact the dealer from whom the unit was purchased. State the Model Number and Serial Number and explain the problem. The Model and Serial Number plate is located inside unit at upper right hand corner.

If you need to locate a service company, you can go online at www.U-LineService.com and search for a service company by zip code.

For more than four decades, U-Line has distinguished itself as the leader in built-in undercounter ice making, refrigeration and wine storage appliances.

Échelon™ SERIES / *Origins* SERIES

U-Line Corporation, located in Milwaukee, WI, is a family operated manufacturer of built-in undercounter icemakers, Combo® icemaker/refrigerators, Wine Captain® wine storage units, refrigerators, refrigerated drawers and refrigerator/freezers.