



Stainless



Overlay

Solid door
overlay

2175BEVC

2000 SERIES

FEATURES

PERFORMANCE

- 5.6 cubic feet overall storage capacity allows for up to 16 (.75L) wine bottles, 48 – 12 oz beer bottles and 65 – 12 oz cans
- Touch glass digital control featuring easy view command center manages key functions and provides user alerts such as an audible door open alarm
- Digital controlled single-zone convection cooling system provides a stable and consistent environment for optimum beverage storage
- Temperature setting from 34 to 45° F and approved for supplemental refrigeration of meat and dairy products
- Sabbath / Blackout mode turns off all lighting, controls display and automatically resets after 36 hours
- ENERGY STAR® / CEE Tier 1 rated makes this the first ENERGY STAR® Beverage Center
- UL residential and commercial listings

INTERIOR / EXTERIOR

- Lighted black interior optimizes elegant display and easy viewing of contents and can be manually turned on for display of contents with door closed; automatically shuts off after four hours
- Two solid beech wood trimmed, full-extension black vinyl coated wine racks allow for full access to stored wines
- Two 6mm tempered glass shelves with bullnose edge to maximize storage potential
- Standard commercial stainless steel handle is interchangeable with professional handle option on stainless model
- Self-closing door ensures a positive door seal and prevents door bounce back
- Stainless Steel and Overlay models come with a field reversible door
- LowE coated, argon gas filled thermopane glass door provides protection from potentially harmful UV rays and added insulating energy efficiency
- Black vinyl clad textured cabinet is more resistant to scratching, peeling and flaking

INTEGRATION

- Solid beech wood trim on wine racks can be stained to match surrounding cabinetry
- Unit can be built-in or freestanding providing a custom aesthetic
- Overlay model accepts a full 3/4" overlay frame and can be fully integrated into all styles of cabinetry with zero clearance
- Allow a 2-1/2" clearance on hinged side for 90° door opening when installed adjacent to a wall (for stainless steel model)
- Allow 1/4" width overall for proper installation (see backside for details)
- No additional clearance around sides, top or rear of unit is needed for ventilation
- Durable, factory installed level legs provide a more precise undercounter fit
- Do not obstruct front grille air flow



Single Zone Convection
Cooling System
featured in 2175BEVC.



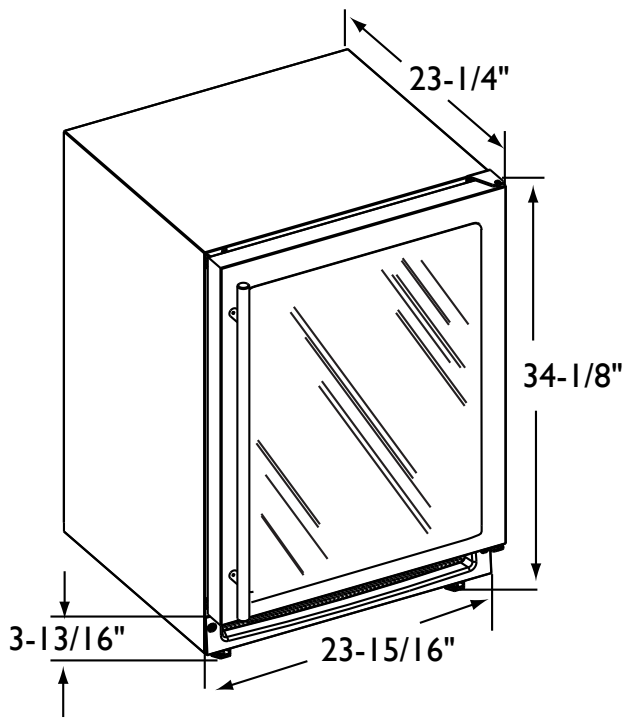

2175BEVCS Stainless Model

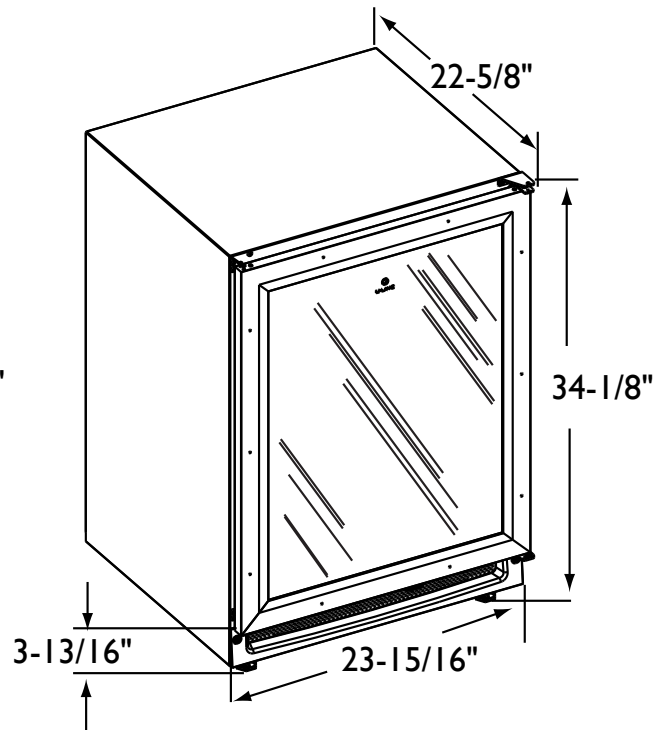

2175BEVCOL Overlay Model
* Not including wood overlay frame

DIMENSIONS AND SPECIFICATIONS

OVERALL DIMENSIONS

- Height 34-1/8" (86.6)
- Width 23-15/16" (60.8)
- Depth 23-1/4" (59.1)
- With stainless steel handle 25-1/8" (63.8)
- Shipping weight:** 120 lbs (54 kg)
- Running amps 2.4
- Maximum start-up amps 9.8
- Amps pertain to voltage rating 110/115 volt, 60 Hz
- ENERGY STAR® and CEE Tier I**

Capacities:

- Defrost technology Automatic
- Refrigerator volume 5.6 Cu. Ft
- Wine bottle storage (0.75L) Up to 16
- Shelf storage Up to 48 12 oz bottles and 65 12 oz cans

2175BEVC	
Stainless	U-2175BEVCS-00
2175BEVCOL	
Overlay	U-2175BEVCOL-00
Solid door overlay	U-2175BEVCOL-60

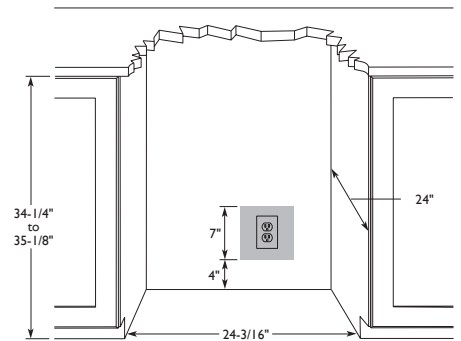

Please visit www.u-line.com for installation guide.

All specifications are subject to change without notice.

