



Stainless

Overlay

2175RCG

2000 SERIES

FEATURES

PERFORMANCE

- 5.4 cubic feet overall capacity maximizes storage
- Touch glass digital control featuring easy view command center manages key functions and provides user alerts such as an audible door open alarm
- Digital controlled single-zone convection cooling system provides a stable and consistent environment for optimum food and beverage storage
- Temperature setting from 34 to 45° F
- Sabbath / Blackout mode turns off all lighting, controls display and automatically resets after 36 hours
- Automatic defrost
- ENERGY STAR® / CEE Tier 1 rated
- UL residential and commercial listings

INTERIOR / EXTERIOR

- Dual lighted black interior optimizes elegant and easy viewing of contents
- Three 6mm tempered glass shelves with bullnose edge to maximize storage potential
- Convenient crisper drawer for proper storage and humidity control of perishable items
- Standard commercial stainless steel handle is interchangeable with professional handle option on stainless steel model
- Stainless Steel and Overlay models come with a field reversible door
- Overlay model door comes ready for overlay application
- LowE coated, argon gas filled thermopane glass door provides protection from harmful UV rays and added insulating energy efficiency
- Black vinyl clad textured cabinet is more resistant to scratching, peeling and flaking

INTEGRATION

- Unit can be built-in or freestanding providing a custom aesthetic
- Overlay model accepts a full 3/4" overlay frame and can be fully integrated into all styles of cabinetry
- Allow a 2-1/2" clearance on hinged side for 90° door opening when installed adjacent to a wall (for stainless steel model)
- Allow 1/4" width overall for proper installation (see backside for details)
- No additional clearance around sides, top or rear of unit is needed for ventilation
- Durable, factory installed level legs provide a more precise undercounter fit
- Do not obstruct front grille air flow

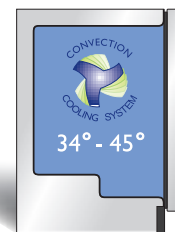

Single Zone
Convection Cooling
System featured in
2175RCG.



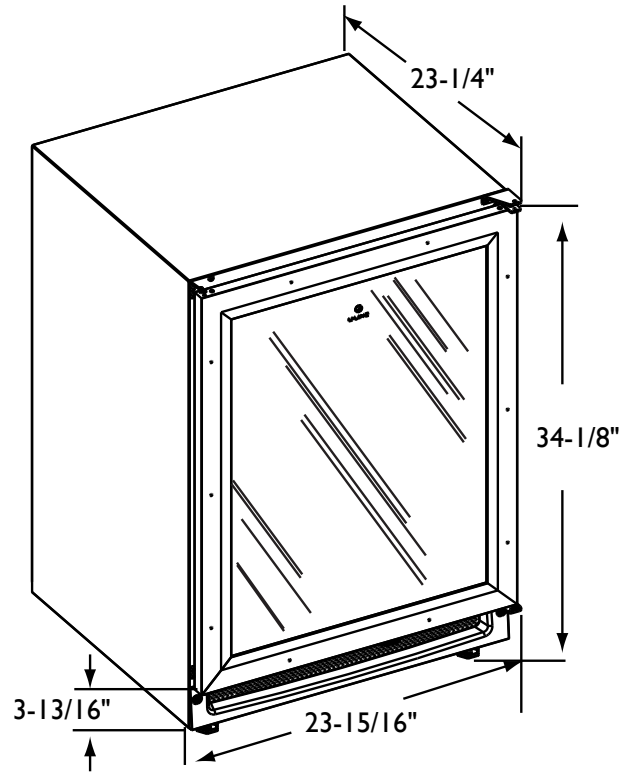

2175RCG

DIMENSIONS AND SPECIFICATIONS

OVERALL DIMENSIONS

Height	34-1/8" (86.6)
Width	23-15/16" (60.8)
Depth	23-1/4" (59.0)
With stainless steel handle	25-1/8" (63.8)

Shipping weight:

Overlay model	122 lbs (55 kg)
Stainless model	1116 lbs (53 kg)

Running amps	2.4
Maximum start-up amps	9.8
Amps pertain to voltage rating	110/115 volt, 60 Hz
ENERGY STAR® and CEE Tier I	

Capacities:

Defrost technology	Automatic
Refrigerator volume	5.4 Cu. Ft

2175RCG

Stainless	U-2175RCGS-00
Overlay	U-2175RCGOL-00

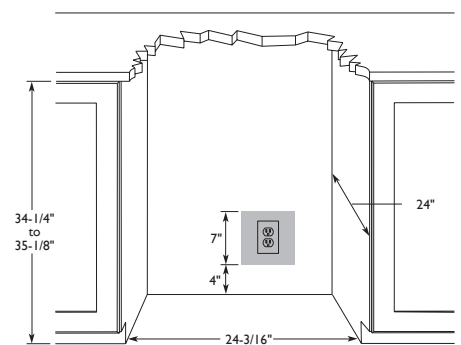

Please visit www.u-line.com for installation guide.

All specifications are subject to change without notice.