



Stainless

Black

ADA151M

ADA SERIES

FEATURES

PERFORMANCE

- Daily ice rate of up to 25 lbs of crescent ice
- Stores up to 25 lbs of ice
- Uses less than 3 gallons of water to produce 25 lbs of ice, conserving both energy and water
- Uses less energy than a 75 watt light bulb
- Perfect size crescent ice cubes (1/2"W x 3/4"H x 2-1/2"L)
- Mechanical control monitors ice making operation to ensure maximum daily ice production
- Manual defrost
- UL residential and commercial listings

INTERIOR / EXTERIOR

- 32" height meets ADA height requirement
- No drain required, easy and inexpensive to install and requires only a 1/4" outside diameter water line
- Stainless steel wrap door with black end caps on stainless model must be ordered left or right hand hinged
- Black door model is field reversible
- Standard commercial stainless steel handle is interchangeable with professional handle option on stainless steel model
- Black vinyl clad textured cabinet is more resistant to scratching, peeling and flaking

INTEGRATION

- Unit can be built-in or freestanding providing a custom aesthetic
- Black model will accept a 1/4" insert panel to match with surrounding decor
- Allow a 2-1/2" clearance on hinged side for 90° door opening when installed adjacent to a wall (for stainless steel model)
- Allow 1/4" width overall for proper installation (see back side for details)
- No additional clearance around sides, top or rear of unit is needed for ventilation
- Durable, factory installed leveling legs provide a more precise undercounter fit
- Do not obstruct front grille air flow



No ice shortages here. Produces up to 25 pounds of crescent ice (1/2" W x 3/4" H 2-1/2" L) per day. No drain required.

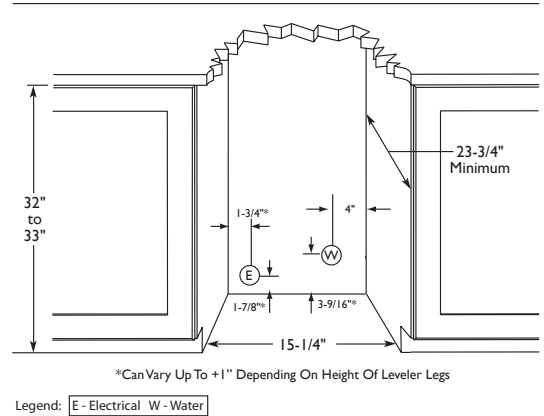
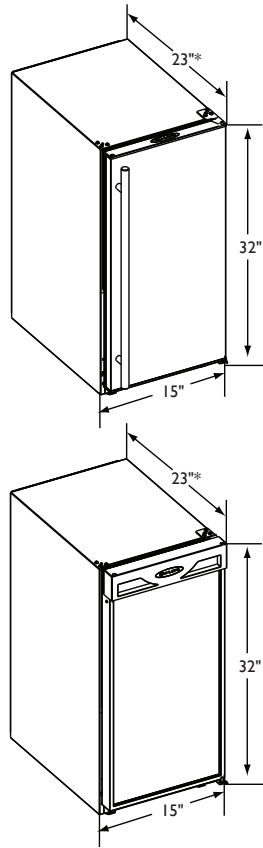

**ADA151MS Stainless Model and
ADA151MB Black Model**
* Add 3/4" for water line clearance

DIMENSIONS AND SPECIFICATIONS

OVERALL DIMENSIONS

Height	32" (81.2)
Width	15" (38.1)
Depth – black model	23" (69)
With stainless steel handle	24-7/8" (63)
Shipping weight	86 lbs (39 kg)
Running amps	2.5
Maximum start-up amps	18.0
Amps pertain to voltage rating	110/115 volt, 60 Hz

Capacities:

Approximate daily ice production	Up to 25 lbs
Ice storage	Up to 25 lbs
Manual defrost	

Optional in 220/230 voltage, 50/60 Hz
On the 220/230 volt models, amps are decreased by approximately 50 percent.

ADA151M	
Stainless Right-hand	U-ADA151MS-00
Stainless Left-hand	U-ADA151MS-01
Black	U-ADA151MB-00

Please visit www.u-line.com for installation guide.
All specifications are subject to change without notice.

