



Stainless

Black

## ADA24RGL

**ADA SERIES**

### FEATURES

**PERFORMANCE**

- 5.3 cubic feet overall capacity allows for storage of more than 7-1/2 cases of 12 oz beverages
- Touch pad digital control featuring easy view command center manages key functions and provides user alerts such as a door open alert
- Digital controlled single-zone convection cooling system provides a stable and consistent environment for optimum food and beverage storage
- Temperature setting from 34 to 45° F
- Sabbath / Blackout mode turns off all lighting, controls display and automatically resets after 36 hours
- Automatic defrost
- ENERGY STAR® / CEE Tier 1 rated
- UL residential and commercial listings

**INTERIOR / EXTERIOR**

- 32" height meets ADA height requirement yet maximizes allowable space
- 4 heavy duty chrome wire shelves
- Standard commercial stainless steel handle is interchangeable with professional handle option on stainless steel model
- Stainless steel model has stainless wrap door with black end caps and must be ordered left or right hand hinged
- Black door model is field reversible
- LowE coated, argon gas filled thermopane glass door provides protection from harmful UV rays and added insulating energy efficiency
- Black vinyl clad textured cabinet is more resistant to scratching, peeling and flaking
- Door lock is standard on all models

**INTEGRATION**

- Unit can be built-in or freestanding providing a custom aesthetic
- Allow a 2-1/2" clearance on hinged side for 90° door opening when installed adjacent to a wall (for stainless steel model)
- Allow 1/4" width overall for proper installation (see backside for details)
- No additional clearance around sides, top or rear of unit is needed for ventilation
- Durable, factory installed level legs provide a more precise undercounter fit
- Do not obstruct front grille air flow



Single Zone  
Convection Cooling  
System featured in  
ADA24RGL.



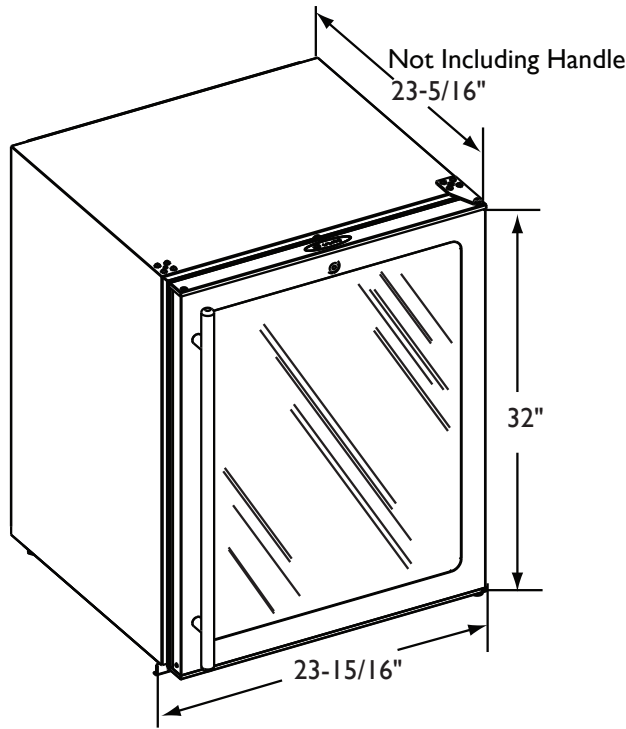

ADA24RGLS Stainless Model

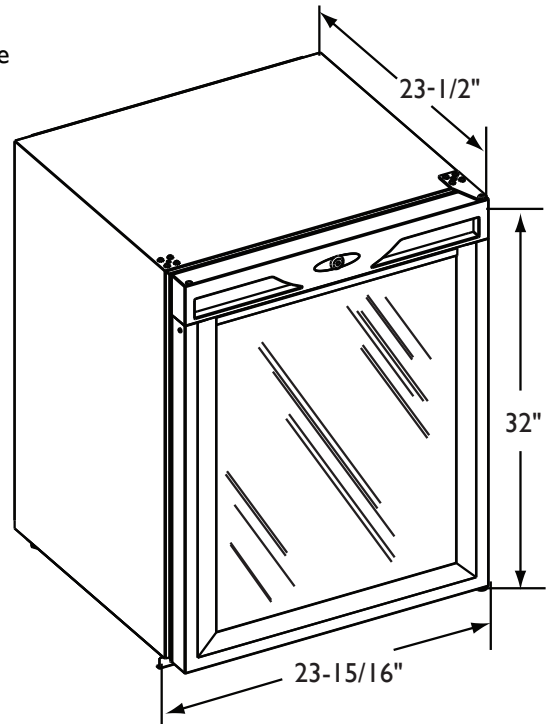

ADA24RGLB Black Model

**DIMENSIONS AND SPECIFICATIONS**

**OVERALL DIMENSIONS**

Height	32" (81.3)
Width	23-15/16" (60.9)
Depth	23-1/2" (59.7)
With stainless steel handle	25-3/8" (64.4)

**Shipping weight:**

Glass Door Model 116 lbs (53 kg)

Running amps	2.4
Maximum start-up amps	9.8
Amps pertain to voltage rating	110/115 volt, 60 Hz
<b>ENERGY STAR® and CEE Tier I</b>	

**Capacities:**

Defrost technology	Automatic
Refrigerator volume	5.3 Cu. Ft
Holds more than 7-1/2 cases of 12 oz canned beverages	

**ADA24RGL**

Stainless Left-hand	U-ADA24RGLS-I3
Stainless Right-hand	U-ADA24RGLS-I5
Black	U-ADA24RGLB-I3

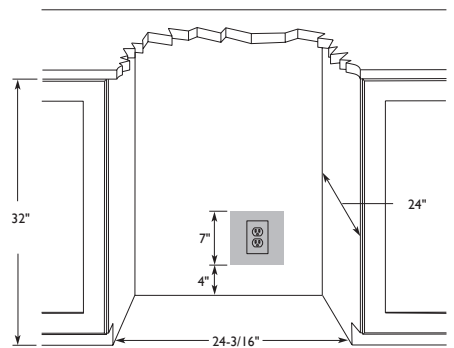

Please visit [www.u-line.com](http://www.u-line.com) for installation guide.

All specifications are subject to change without notice.

