



Stainless



Black

Overlay

## C2275DWR

6444#W VM W

### FEATURES

#### PERFORMANCE

- 3.0 cubic feet overall refrigerator capacity and 2 cubic feet of freezer capacity maximizes storage
- Daily ice rate of up to 6 lbs and storage of up to 10 lbs of crescent ice cubes (1/2"W x 3/4"H x 2-1/2"L)
- No drain, easy and inexpensive installation, only required a 1/4" diameter outside line
- Touch glass digital control featuring easy view command center manages key functions and provides user alerts such as an audible door open alarm
- Digital controlled single-zone convection cooling system provides a stable and consistent environment for optimum food and beverage storage
- Refrigerator temperature setting from 34 to 45° F provides flexibility for preserving a wide variety of items
- Sabbath / Blackout mode turns off all lighting, controls display and automatically resets after 36 hours
- Patented frost-free technology
- UL residential listing

#### INTERIOR / EXTERIOR

- Lighted stainless steel interior allows for easy viewing of contents
- Clear organizing bin in top drawer holds wine, 2-liter bottles and other items and slides back and forth for access to items beneath
- Optional slide and divide organizer must be purchased separately PN: U-26013
- Black vinyl clad textured cabinet is more resistant to scratching, peeling and flaking

#### INTEGRATION

- Overlay can be converted to a black model with purchase of a black handle kit PN: 26070-01
- Due to full extension of drawers, anchoring device included and required for all installations
- Overlay model accepts a full 3/4" overlay panel and can be fully integrated into all styles of cabinetry
- Allow 1/4" width overall for proper installation (see backside for details)
- No additional clearance around sides, top or rear of unit is needed for ventilation
- Durable, factory installed level legs provide a more precise undercounter fit
- Do not obstruct front grille air flow



The Combo® Models bring together abundant ice supply with generous refrigeration capacity in the convenience of one unit.



C2275DWR – Combo® Model drawer delivers three appliances in one. Top drawer holds up to 3 cubic feet of refrigerator space with clear top sliding bin while lower drawer houses both ice maker and freezer.

\*To obtain a black model with a black handle, black integrated kit #26070-01-5 must be ordered.

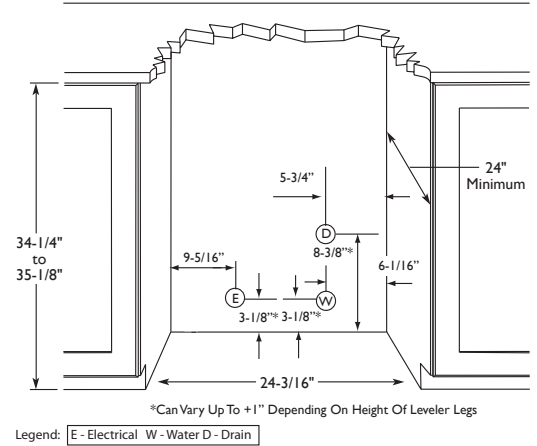
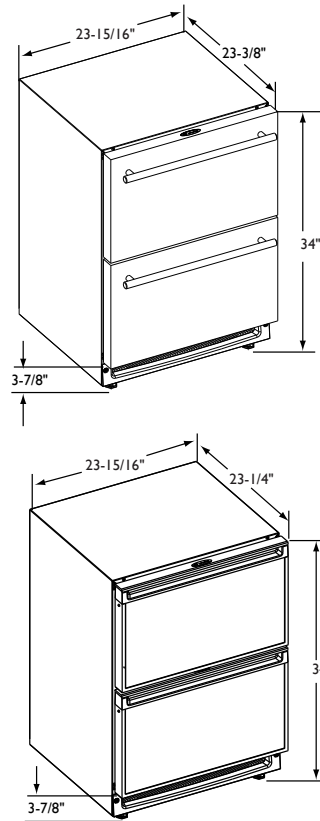

C2275DWRS Stainless Model and  
C2275DWROL Black Model

## DIMENSIONS AND SPECIFICATIONS

### OVERALL DIMENSIONS

Height	34" (86.0)
Width	23-15/16" (60.8)
Depth	23-5/8" (60)
With stainless steel handle	25-1/2" (64.7)

### Shipping Weight:

Black model	158 lbs (72 kg)
Stainless model	162 lbs (74 kg)

Running amps	2.5
Maximum start-up amps	26.5
Amps pertain to voltage rating	110/115 volt, 60 Hz

### Capacities:

Defrost technology	Manual defrost
Refrigerator volume	3 Cu. Ft
Freezer volume	2 Cu. Ft
Approximate daily ice production	Up to 6 lbs
Ice Storage	Up to 10 lbs

### C2275DWR

Stainless	U-C2275DWRS-00
Black	U-C2275D-WROL-00 with Black Integrated handle 26070-01-S
Overlay	U-C2275DWROL-00

Please visit [www.u-line.com](http://www.u-line.com) for installation guide.

All specifications are subject to change without notice.