

Custom 1/4" Door Panel: 28-5/32" H x 14-1/32" W (71.5 cm x 35.6 cm)
 3/4" Full Overlay Panel: 29-7/8" H x 14-3/4" W (75.9 cm x 37.5 cm)

See Overlay Door Panel Preparation Instructions

A Clear Ice Maker which produces up to 60 pounds of ice per day and stores up to 30 pounds.

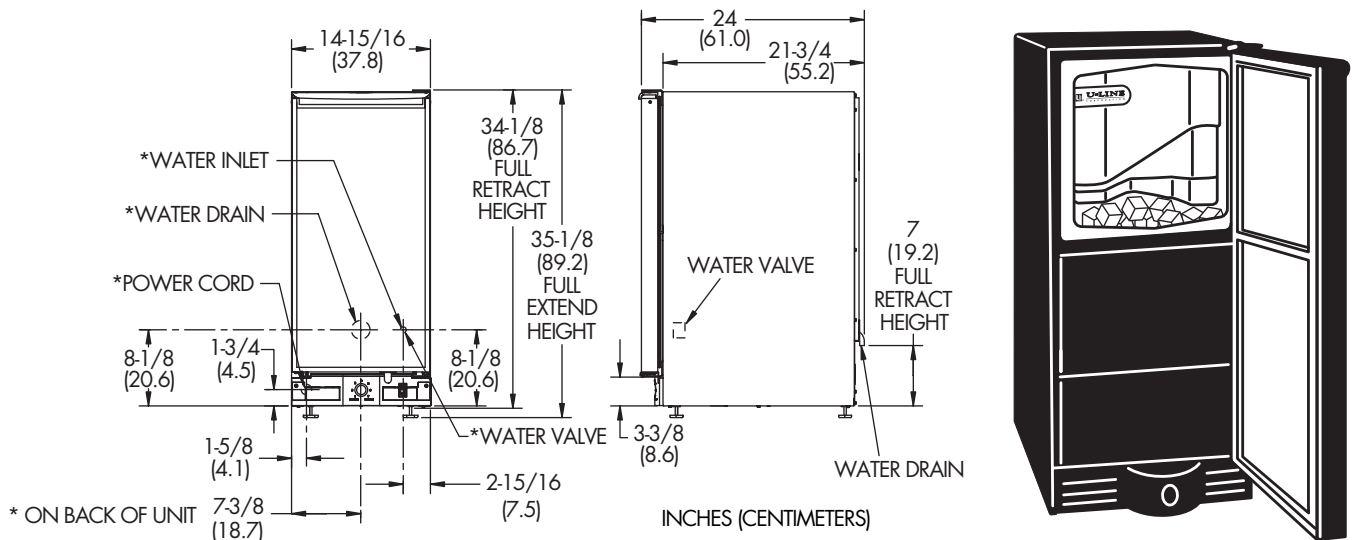

EXCLUSIVE FEATURES OF ÉCHELON™

- High daily ice production and storage capability**
BENEFIT: Produces up to 60 pounds of ice per day and stores up to 30 pounds.
- An EXCLUSIVE FEATURE of the Échelon™ Series is an optional full overlay door capability (panel kit) using a 3/4 inch thick panel**
BENEFIT: Provides a fully integrated appearance with surrounding cabinets. Overlay panel is easily attached to the door.
- Automatic electronic control module that controls daily ice production**
BENEFIT: Maximizes the daily ice production by monitoring and automatically making adjustments for changes in the ambient room and water temperatures. Provides for a consistently shaped ice cube.
- Easy, self-cleaning process**
BENEFIT: Eliminates any complicated procedures or time consuming process in order to clean the ice maker. Just empty the ice bin, turn the switch to "Clean," and add the U-Line cleaner fluid after the water reservoir fills. In approximately 45 minutes the ice maker has automatically completed a series of cleaning and rinsing cycles and is ready to start producing ice once the switch is turned to the "Ice" position.
- Quietest ice maker in its class**
BENEFIT: Up to twice as quiet during its ice making and ice storage operation than some competitive models.
- Seven (7) inch drain height extending from the rear of the CLR2060**
BENEFIT: Allows for more installation flexibility in the respect that the higher the drain height the further the CLR2060 can be located from the gravity feed drain.

SUPERIOR FEATURES OF ÉCHELON™

1. **Standard, all doors (except stainless steel units) come with a flush mounted door panel and will accept a custom 1/4 inch thick panel.**

BENEFITS: A standard feature to achieve a custom, built-in look by matching surrounding cabinets.

2. **Self closing hinges when door is open approximately 8-10 inches**

BENEFITS: Ensures a positive door seal and prevents door bounce back.

3. **A slightly contoured, across the top, handle design for black and white units**

BENEFITS: The contoured handle shape maintains the stylized shape of the Échelon™ series plus permits full field reversibility of the door for black and white units.

4. **All stainless units have a seamless full wrap stainless steel cabinet and door with sculpted, contoured handle.**

BENEFIT: This seamless full wrap stainless steel door with sculpted stainless handle distinguishes the Échelon™ stainless steel units from other heavier "commercial" looks. All stainless steel units have a full wrap stainless cabinet, stainless hinges, and black grille. All stainless units must be ordered either right or left hand hinged and are not field reversible.

5. **The CLR2060 stainless steel unit is deemed suitable for outdoor use by UL.**

BENEFIT: For those outdoor applications that require products deemed suitable for outdoor use by UL, the CLR2060 stainless steel unit meets these requirements.

6. **"L" shaped hinges**

BENEFIT: This hinge design provides greater door support thereby permitting larger and heavier door panels and full overlay doors to be utilized.

7. **Field reversible doors (except stainless steel).**

BENEFIT: Greater flexibility where the unit can be installed and allows for side-by-side applications.

8. **Drain pump available when access to a gravity drain is not an option**

BENEFIT: The P60 drain pump is specifically designed for the CLR2060. It is a fully sealed pump that contains an "automatic shut-off logic." Both features reduce the risk of water overflow in the event of a drain back up or unit malfunction.

ADDITIONAL FEATURES

1. Frost Free Technology
3. Built-in or freestanding
4. Vinyl clad steel cabinet (black/white)
5. Adjustable leveling legs
6. Available in black, white and stainless steel

BENEFITS

Never needs defrosting.

Provides custom look. No additional clearance around sides, top or rear for ventilation.

Do not obstruct the front grille.

Textured, rich look. Resistant to scratching, peeling and flaking.

More precise under the counter fit, durable – factory installed.

Blends with all cabinet colors.